

Plug-in systems Main catalog

Slide-inline | Industrial connectors

EN

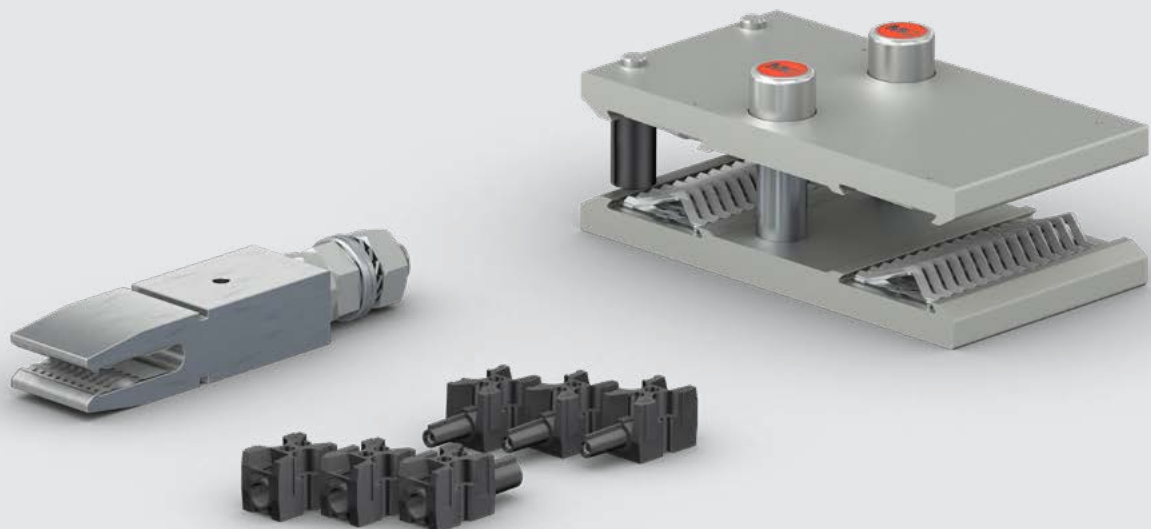

STÄUBLI ELECTRICAL CONNECTORS

Long-term solutions – Expert connections



Stäubli Electrical Connectors is a leading international manufacturer of high-quality electrical contacts and connector systems and solutions for industrial applications. We are part of the Stäubli mechatronics group, the technology leader in connection solutions, robotics and textile machinery.

Pioneering contact technology for increased efficiency

The entire Stäubli Electrical Connectors product range meets market expectations for high performance, the highest number of mating cycles, and long-lasting reliability for safe, durable operation. Our proven **MULTILAM technology** is ideal for all types of connections in industrial applications.

Customers in the **power transmission and**

Stäubli develops, produces, sells and services products for markets with the highest productivity and safety standards. As recognized specialists, our focus is always on solutions and customers. Many new developments got their start here and are now becoming established as worldwide standards.

distribution sector rely on our consistent, loss-free transmission performance in all voltage ranges. The **automotive industry** depends on our high-efficiency connections for spot-welding applications in production lines. Harsh conditions in the **transportation sector** require high vibration resistance, maximum reliability, and compact design. These attributes are vitally important for railway and e-mobility applications. The safety

Our customers depend on our expertise and our active support, even when dealing with unusual challenges. With Stäubli, you're entering into a long-term partnership built on reliability, dedication, and exceptional quality in both products and services.

and reliability of our products are essential for **test and measurement technology**.

In the growing field of **alternative energy**, our products have been setting standards since the 1990s. About half of the solar energy generated worldwide is transmitted through safe, long-lasting, high-performance Stäubli connectors.

Applications and benefits

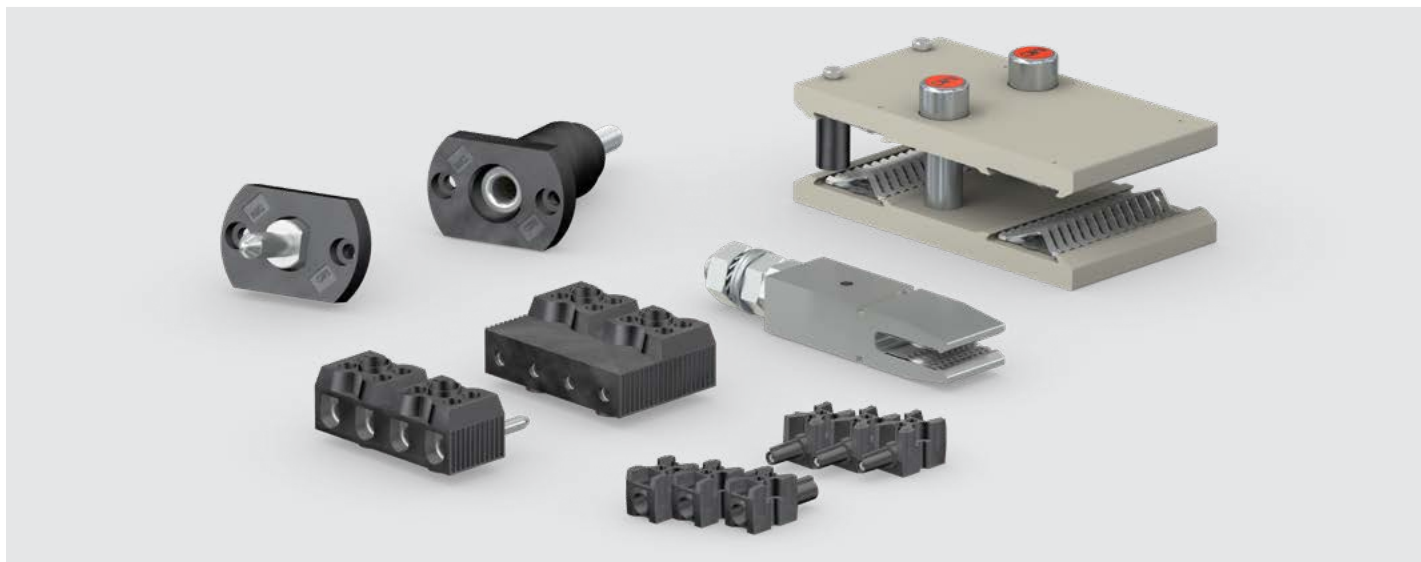

The versatile fork or round connectors for plug-in technology and busbars from Stäubli's wide range of solutions are perfectly suited to a variety of industries and applications with the most demanding requirements.

The single- and multi-pole round plugs are a safe and efficient solution for plug-in modules used for power supply, energy storage, in frequency converters or power supply filters. Fork plugs can be connected to busbars easily and with flexibility: The double-sided fork allows for a quick and robust

connection between two busbars without any difficulty.

The round and fork connector can be used to replace costly screw connectors, increase productivity and reduce installation and service costs. In addition, they also enable more compact constructions for e.g. rack systems. At the heart of all Stäubli connectors lies the tried and tested, reliable MULTILAM contact technology. Thanks to decades of experience and expertise, Stäubli also offers entirely customer-specific solutions.

Properties and benefits:

- High current carrying capacity
- Minimal contact heating
- High vibration and shock resistance and extreme robustness
- High number of mating cycles
- Compensation of angular and axial offsets

Content

- Page 6** **Round connectors for plug-in systems**
- Introduction
 - Socket and plug modules P1/30-...
 - Socket and plug modules P1/63-...
 - Socket and plug blocks P4/50... and P4/63...
 - Socket and plug modules P1/100-...
- Page 20** **Slide-in sockets and plugs EB...**
- Page 25** **Fork plugs GSR5/... for busbars**
- Introduction
 - Fork plug with crimp termination
 - Fork plug with screw termination
 - Insulating housing
 - Terminations, current carrying capacity and arrangement
- Page 32** **Double fork plugs GSRD...**
- Page 35** **Stäubli special fork plugs for busbars**
- Page 38** **Annexe**
- Derating diagrams
 - Technical information
 - Index

General information

Changes / Provisos

All data, illustrations and drawings in the catalogue have been carefully checked. They are in accordance with our experience to date, but no responsibility can be accepted for errors.

We also reserve the right to make modifications for design and safety reasons. When designing equipment incorporating our components, it is therefore advisable not to rely solely on the data in the catalogue but to consult us to make sure this information is up to date. We shall be pleased to advise you.

Copyright

The use of this catalogue for any other purpose, in whatever form, without our prior written consent is not permitted.

RoHS ready

Directive 2011/65/EC on the restriction of the use of certain hazardous substances in electrical and electronic equipment.

Symbols



Accessories or special tools exist for this product

www.staubli.com/electrical



The assembly instruction MA000 is available for this product

www.staubli.com/electrical

ROUND CONNECTORS FOR PLUG-IN SYSTEMS

Introduction

P1/...



1-pin elements that can be used in a chain

P4/...



Compact 4-pole unit

Ø 4 mm

Range of **3** modular sizes

Ø 2 mm

P1/30...
30 A



with screw
termination

Ø 4 mm

P1/63...
63 A



Ø 6 mm

P1/100
100 A

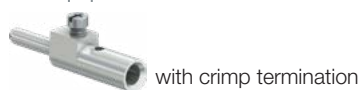

with crimp termination

or



with screw
termination

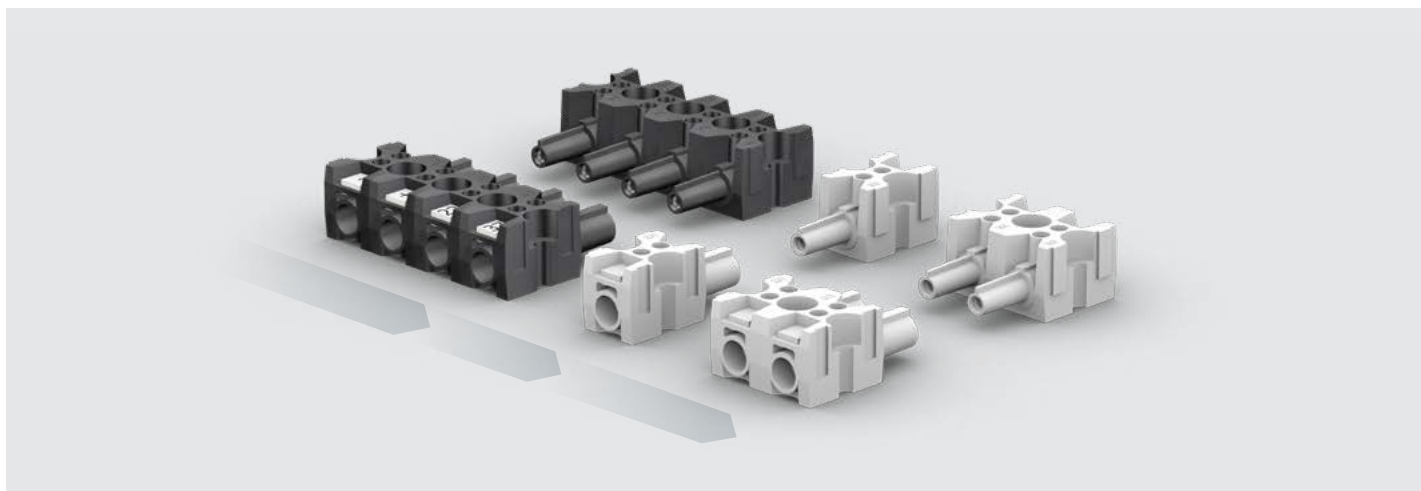

(P1/...) Up to 10 modules can be joined together

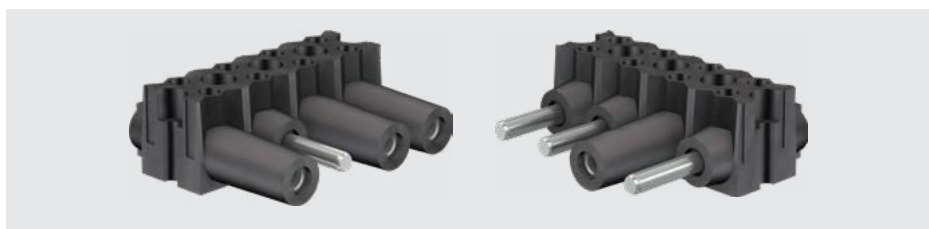

(P1/...) Provision for coding if modules of the same nominal diameter are mixed

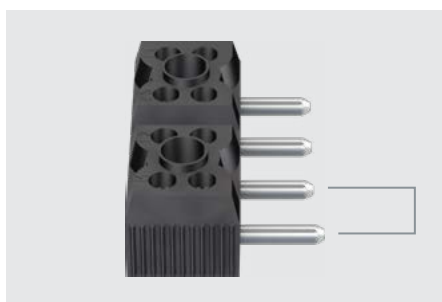

Long version of plug for leading contact



The floating contact part is mounted in the insulation by means of a threaded pin



The sockets of P1/... and P4/... round connectors are fitted with the proven Stäubli MULTILAMs

Socket and plug modules P1/30...

With screw termination

P1/30-BS
Socket

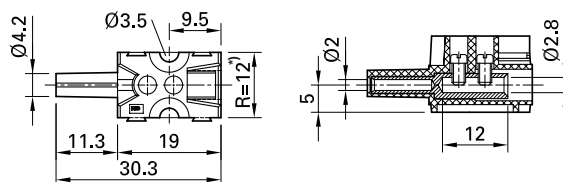
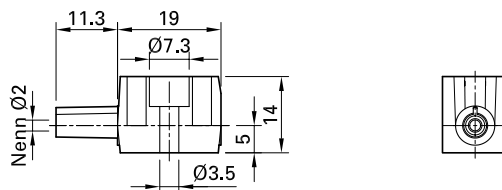

P1/30-SS...
Plug

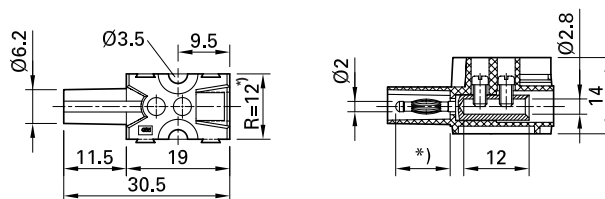
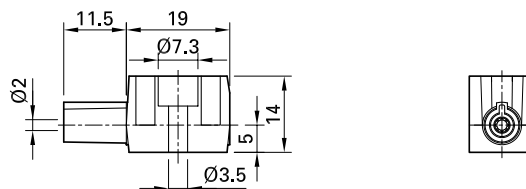

Technical data

for conductor cross section	2.5 mm ² /14 AWG
Rated current	30 A, see derating diagram page 38
Rated voltage	500 V
Short-circuit current	0.29 kA/1 s 0.17 kA/3 s
Test voltage (50 Hz, 1 min.)	2.21 kV (UL: 2 kV) ¹⁾
Flashover voltage (50 Hz)	5 kV
Contact resistance	500 µΩ
Contact material	brass, silver plated
Insulation coordination ²⁾	4 kV/2
Insulation material/Flame rating	PC/UL94-V0
Withdrawal force	4 N
Maximum temperature rise	45 K (UL 1977 – Section 16)
Temperature range	-40 °C...+125 °C



Assembly instructions MA081

www.staubli.com/electrical

^{*)} Long version = 12/short = 10

R = Raster dimension

¹⁾ See page 42: UL Engineering considerations

²⁾ Valid between live parts and mounting surface



Marking facility (e.g. with Dekafix DEK5 (www.weidmueller.de))







Keyed to protect against wrong insertion

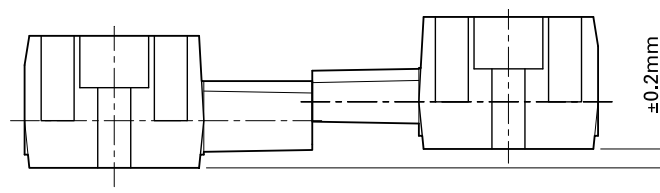
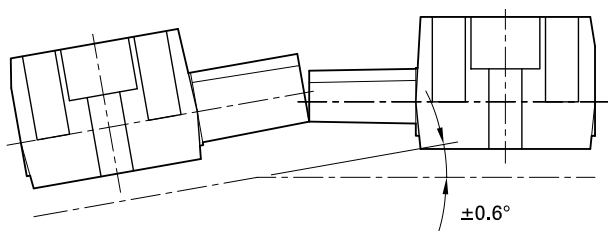

P1/30-BS and P1/30-SSK are touch protected in unmated condition

Maximum mounting offset



Order No.	Type	Description	UL Approval	Delivered
15.0188	P1/30-BS	Socket	 ¹⁾	assembled
15.0186	P1/30-SSK	Plug	 ¹⁾	assembled
15.0187	P1/30-SSL ²⁾	Plug	 ¹⁾	assembled

Note:

Commercial wire-end ferrules are to be used when connecting flexible leads.

¹⁾ See page 42: UL Engineering considerations

²⁾ With leading pin

Socket and plug modules P1/63...

With crimp termination

P1/63-B10

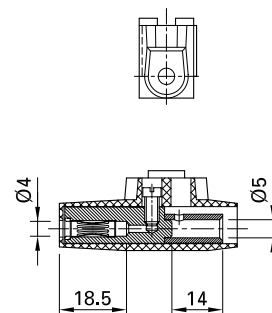
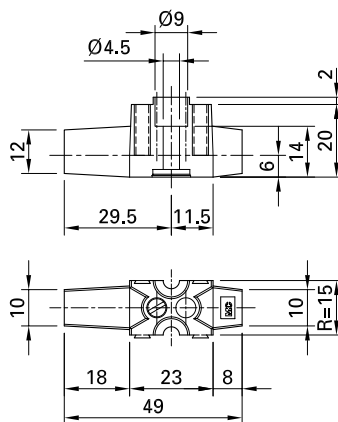

P1/63-S10...

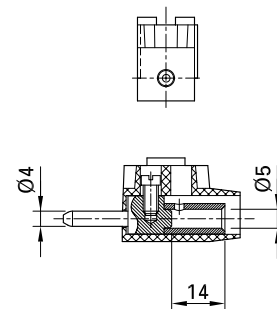
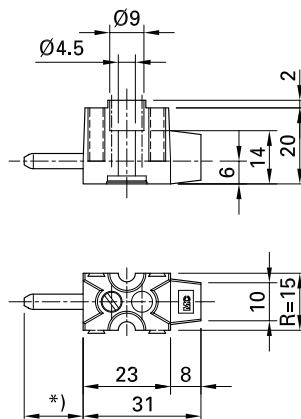

Technical data	
for conductor cross section	10 mm ² /8 AWG
Rated current	63 A, see derating diagram page 38
Rated voltage	500 V/600 V ¹⁾²⁾
Short-circuit current	1.2 kA/1 s 0.85 kA/3 s
Test voltage (50 Hz, 1 min.)	2.21 kV/3.51 kV ¹⁾ (2 kV ³⁾)
Flashover voltage (50 Hz)	6 kV/9 kV ¹⁾
Contact resistance	250 µΩ
Contact material	brass, silver plated
Insulation coordination ⁴⁾	6 kV/2 ⁵⁾ /6 kV/3 ⁶⁾
Insulation material/Flame rating	PC/UL94-V0
Termination	Crimping
Withdrawal force	5 N
Maximum temperature rise	49 K(UL 1977 – Section 16)
Temperature range	-40 °C...+125 °C

*) Long version = 17.5/short = 15.5
R = Raster dimension

¹⁾ With spacer D-P4/50PC, see page 13

²⁾ Includes 400 V/690 V (IEC 60038)

³⁾ See page 44: UL Engineering considerations

⁴⁾ Valid between live parts and mounting surface

⁵⁾ To attachment with metal cheese headed screws

⁶⁾ To attachment with plastic cheese headed screws

Maximum mounting offset

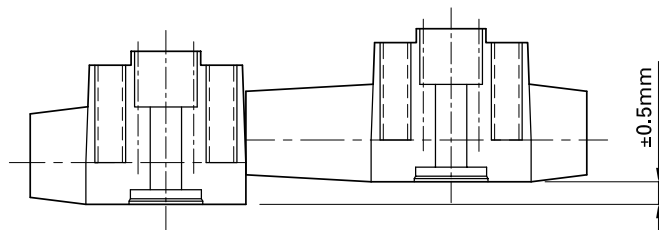
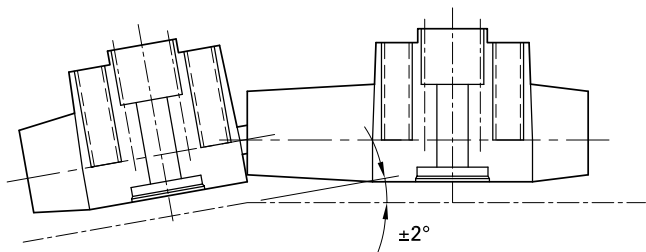

No.	Order No.	Type	Description	UL Approval	Delivered
1	15.0184	P1/63-B10	Socket		unassembled
2	15.0184	P1/63-B10	Socket		unassembled ²⁾

Individual parts

3	01.0414	BP4-P1/63-10	Socket		
4	15.5256	I-P1/63-B	Insulation, black		
5	15.5032	SCH-P4/50	Cheese headed screw		
6	15.5035	D-P4/50PC	Spacer, black		

7	15.0180	P1/63-S10K	Plug		unassembled
7	15.0182	P1/63-S10L ³⁾	Plug		unassembled
8	15.0180	P1/63-S10K	Plug		unassembled ²⁾
8	15.0182	P1/63-S10L ³⁾	Plug		unassembled ²⁾

Individual parts

9	05.0403	SP4-P1/63-10K	Pin		
10	05.0404	SP4-P1/63-10L	Leading pin		
11	15.5255	I-P1/63-S	Insulation, black		
5	15.5032	SCH-P4/50	Cheese headed screw		
6	15.5035	D-P4/50PC	Spacer, black		

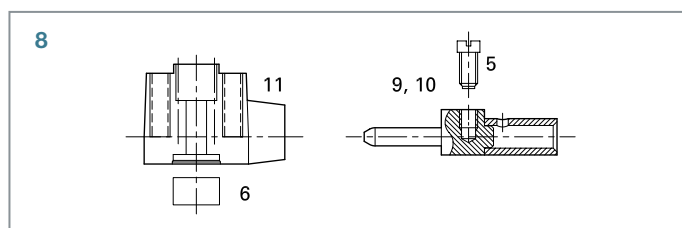
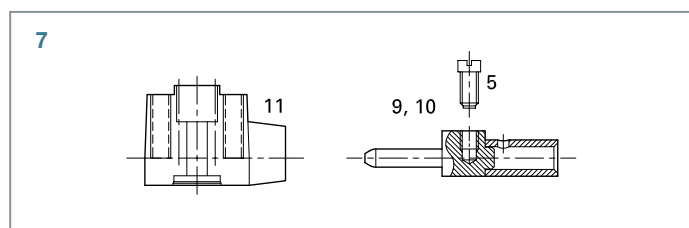
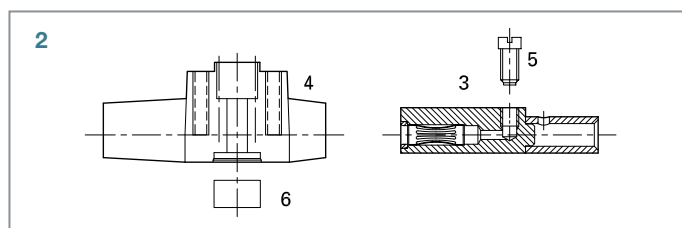
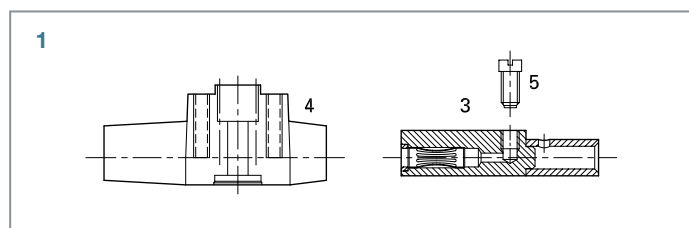

¹⁾ See page 42: UL Engineer considerations

²⁾ Please order the spacer 600 V D-P4/50PC (Pos. No. 6) separately.

³⁾ With leading pin

Socket and plug modules P1/63...

With screw termination

P1/63-BS

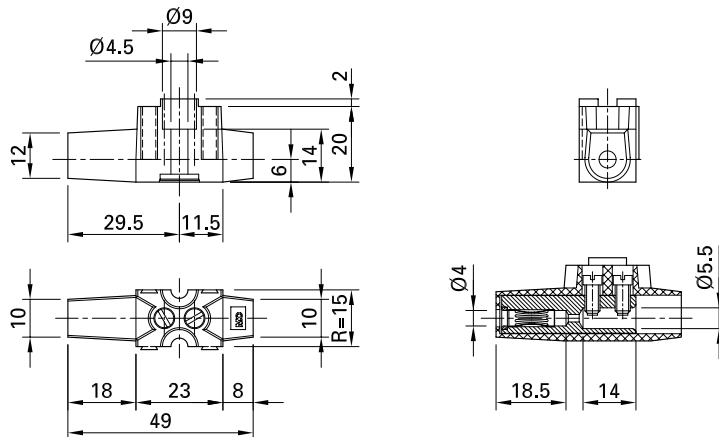

P1/63-SS...

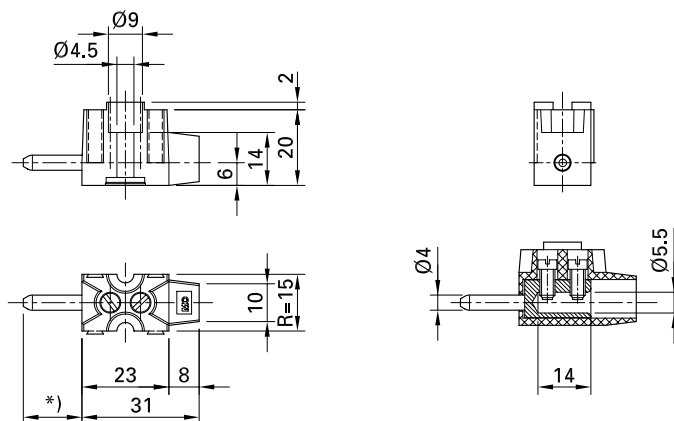

Technical data

for conductor cross section	10 mm ² /8 AWG
Rated current	63 A, see derating diagram page 38
Rated voltage	500 V/600 V ¹⁾²⁾
Short-circuit current	1.2 kA/1 s 0.85 kA/3 s
Test voltage (50 Hz, 1 min.)	2.21 kV/3.51 kV ¹⁾ (: 2 kV ³⁾)
Flashover voltage (50 Hz)	6 kV/9 kV ¹⁾
Contact resistance	250 µΩ
Contact material	brass, silver plated
Insulation coordination ⁴⁾	6 kV/2 ⁵⁾ /6 kV/3 ⁶⁾
Insulation material/Flame rating	PC/UL94-V0
Withdrawal force	5 N
Maximum temperature rise	49 K (UL 1977 – Section 16)
Temperature range	-40 °C...+125 °C

*) Long version = 17.5/short = 15.5

R = Raster dimension

¹⁾ With spacer D-P4/50PC, see page 11

²⁾ Includes 400 V/690 V (IEC 60038)

³⁾ See page 44: UL Engineering considerations

⁴⁾ Valid between live parts and mounting surface

⁵⁾ To attachment with metal cheese headed screws

⁶⁾ To attachment with plastic cheese headed screws



Assembly instructions MA081

www.staubli.com/electrical

Maximum mounting offset

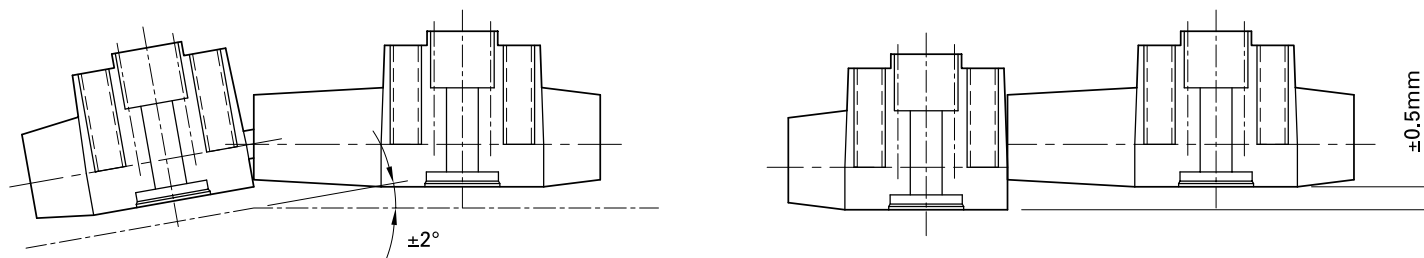

No.	Order No.	Type	Description	UL Approval	Delivered
1	15.0164	P1/63-BS	Socket	¹⁾	assembled ²⁾

Individual parts

2	01.0410	B4-P4/50-B	Socket
3	15.5256	I-P1/63-B	Insulation, black
4	15.5032	SCH-P4/50	Cheese headed screw
5	15.5035	D-P4/50PC	Spacer, black

6	15.0160	P1/63-SSK	Plug	¹⁾	assembled ²⁾
6	15.0162	P1/63-SSL ³⁾	Plug	¹⁾	assembled ²⁾

Individual parts

7	04.0410	S4-P4/50-S17	Pin
8	04.0413	S4-P4/50-S19	Leading pin
9	15.5255	I-P1/63-S	Insulation, black
4	15.5032	SCH-P4/50	Cheese headed screw
5	15.5035	D-P4/50PC	Spacer, black

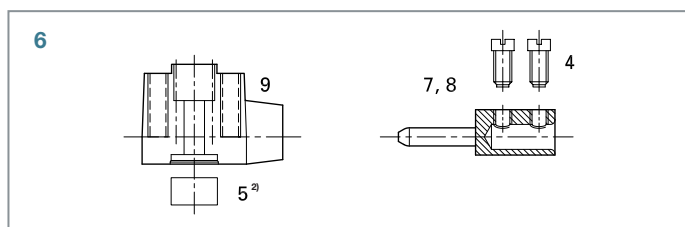
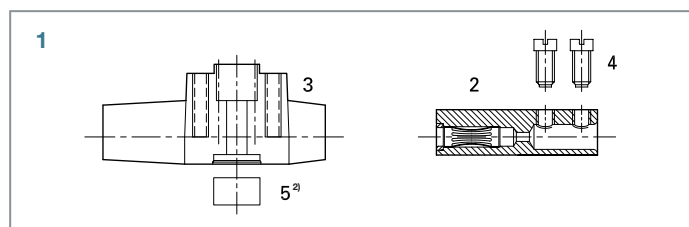

¹⁾ See page 44: UL Engineer considerations

²⁾ Please order the spacer 600 V D-P4/50PC (Pos. No. 5) separately if required.

³⁾ With leading pin

4-pole socket and plug blocks

With screw termination P4/50... und P4/63...

P4/50-B
P4/63-B-PC

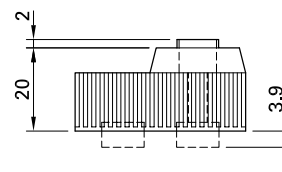
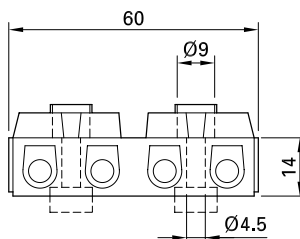

P4/50-B-D
P4/63-B-PCD

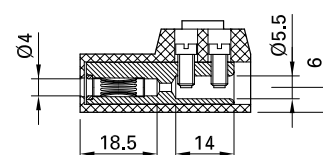
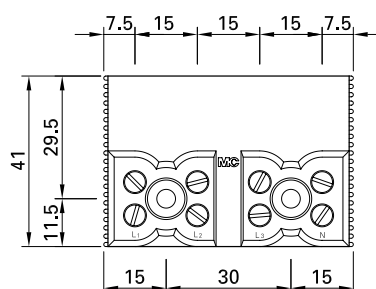

With 4 spacers D-P4/50PC

P4/50-S
P4/63-S-PC

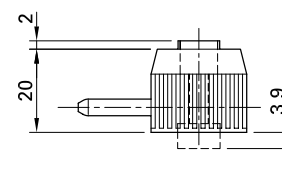
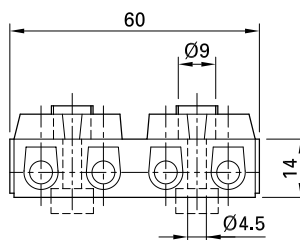

P4/50-S-D
P4/63-S-PCD

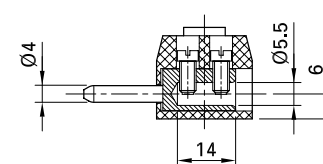
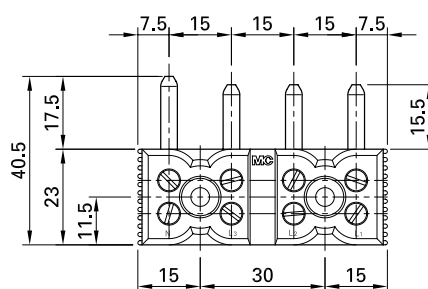

With 2 spacers D-P4/50PC

Mechanical data

for conductor cross section Cu	10 mm ² /8 AWG
Contact material	brass, silver plated
Insulation material black	P4/50..., ABS P4/63..., PC
Flame class	UL94-V0
Withdrawal force	20 N
Maximum temperature rise	59.7 K (UL 1977 – Section 16)
Temperature range	P4/50..., -40 °C...+90 °C P4/63..., -40 °C...+120 °C



Assembly instructions MA081

www.staubli.com/electrical

Electrical data	
Rated current	P4/50..., 50 A P4/63..., 63 A see derating diagram page 38
Rated voltage	500 V/600 V ¹⁾²⁾
Short-circuit current	1.2 kA/1 s 0.85 kA/3 s
Test voltage (50 Hz, 1 min.)	2.2 kV/3.3 kV ¹⁾ (RU : 2 kV ³⁾)
Flashover voltage (50 Hz)	3 kV/4 kV ¹⁾
Contact resistance	250 $\mu\Omega$
Insulation coordination without spacer ⁴⁾	P4/50..., 4 kV/2 P4/63..., 4 kV/1
Insulation coordination with spacer ⁴⁾	6 kV/2 ⁵⁾ 6 kV/3 ⁶⁾

Maximum mounting offset

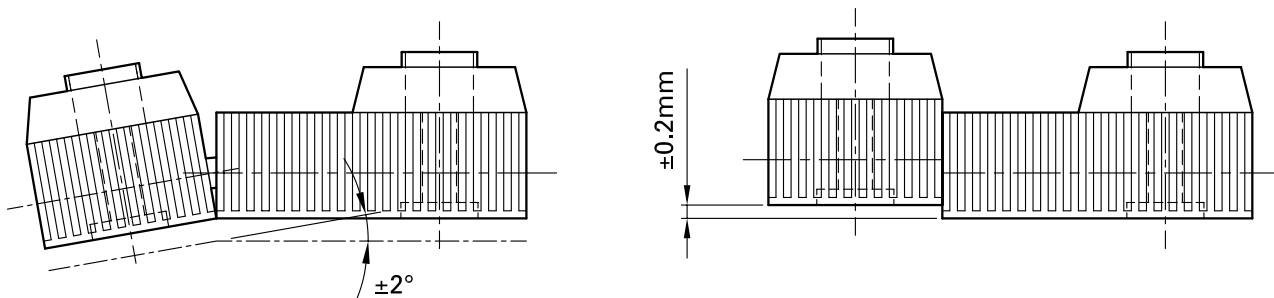

Order No.	Type	Description	UL Approval	Delivered
15.0112	P4/50-B	Socket	$\text{RU}^{3)}$	assembled
15.0114	P4/63-B-PC	Socket	$\text{RU}^{3)}$	assembled
15.0116	P4/50-B-D	Socket	$\text{RU}^{3)}$	assembled
15.0118	P4/63-B-PCD	Socket	$\text{RU}^{3)}$	assembled
15.0111	P4/50-S	Plug	$\text{RU}^{3)}$	assembled
15.0113	P4/63-S-PC	Plug	$\text{RU}^{3)}$	assembled
15.0115	P4/50-S-D	Plug	$\text{RU}^{3)}$	assembled
15.0117	P4/63-S-PCD	Plug	$\text{RU}^{3)}$	assembled

¹⁾ With spacer D-P4/50PC

²⁾ Includes 400 V/690 V (IEC 60038)

³⁾ See page 42: UL Engineering considerations

⁴⁾ Valid between live parts and mounting surface

⁵⁾ To attachment with metal cheese headed screws

⁶⁾ To attachment with plastic cheese headed screws

Socket and plug modules P1/100...

With crimp termination

P1/100-B16

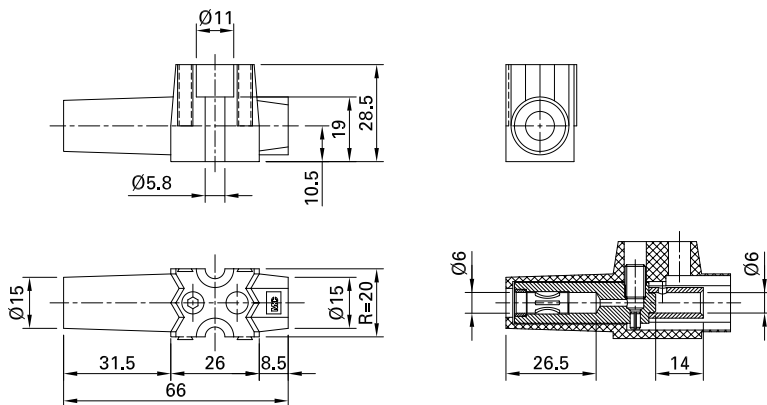

P1/100-S16...

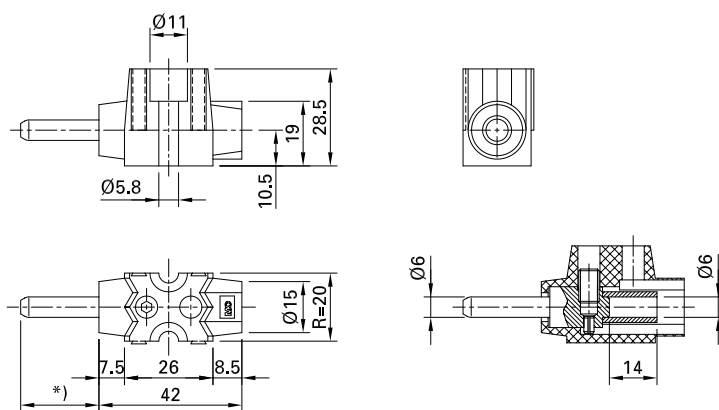

Technical data	
for conductor cross section	16 mm ² /6 AWG
Rated current	100 A, see derating diagram page 38
Rated voltage	600 V ¹⁾
Short-circuit current	2.2 kA/1 s 1.3 kA/3 s
Test voltage (50 Hz, 1 min.)	3.51 kV ( : 2.2 kV) ²⁾
Flashover voltage (50 Hz)	9 kV
Contact resistance	150 $\mu\Omega$
Contact material	brass, silver plated
Insulation coordination	6 kV/2 ³⁾
Insulation material/Flame rating	PC/UL94-V0
Termination	Crimping
Withdrawal force	25 N
Maximum temperature rise	49 K
Temperature range	-40 °C...+125 °C

*) Long version = 26/short = 23

R = Raster dimension

¹⁾ Includes 400 V/690 V (IEC 60038)

²⁾ See page 44: UL Engineering considerations

³⁾ Valid between live parts and mounting surface

Maximum mounting offset

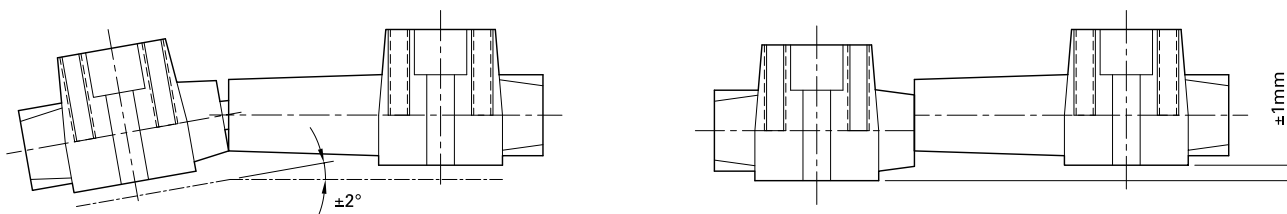

No.	Order No.	Type	Description	Delivered
1	15.0172	P1/100-B16	Socket	unassembled

Individual parts

3	01.0406	BP6-P1/100-16	Socket	
4	15.5252	I-P1/100-B	Insulation, black	
5	15.5253	GWD-STI M6x12 ISO4026 BN28 DIN913 45H	Grub screw, M6x12	

2	15.0170	P1/100-S16K	Plug	unassembled
2	15.0171	P1/100-S16L ¹⁾	Plug	unassembled

Individual parts

6	05.0400	SP6-P1/100-16K	Plug	
7	05.0401	SP6-P1/100-16L	Plug, leading pin	
8	15.5251	I-P1/100-S	Insulation, black	
5	15.5253	GWD-STI M6x12 ISO4026 BN28 DIN913 45H	Grub screw, M6x12	

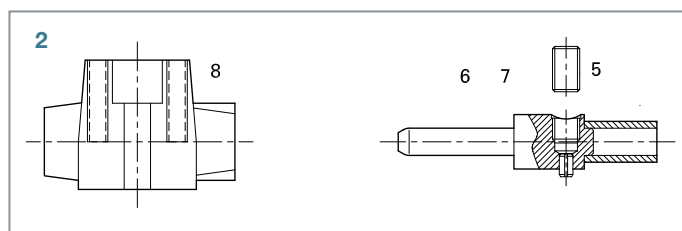
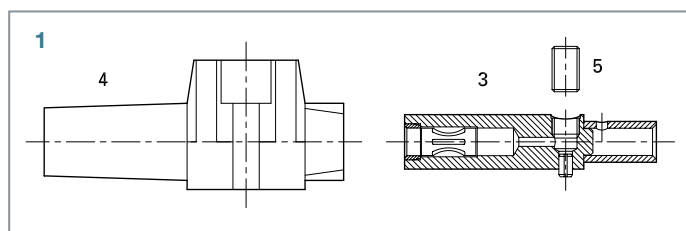

¹⁾ With leading pin

Socket and plug modules P1/100...

With screw termination

P1/100-BS

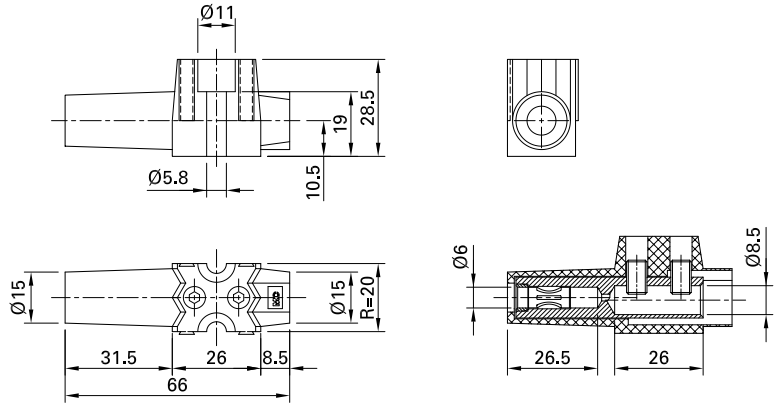

P1/100-SS...

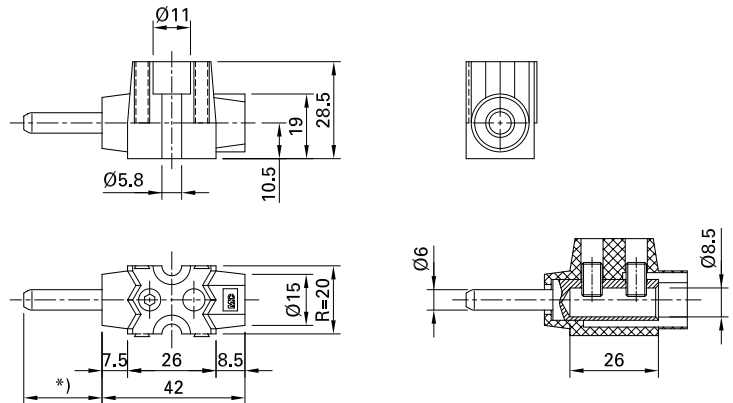

Technical data

for conductor cross section	16 mm ² , 25 mm ² /6 AWG, 4 AWG
Rated current	100 A, 130 A, see derating diagram page 38
Rated voltage	600 V ¹⁾
Short-circuit current	2.2 kA/1 s 1.3 kA/3 s
Test voltage (50 Hz, 1 min.)	3.51 kV ( : 2.2 kV) ²⁾
Flashover voltage (50 Hz)	9 kV
Contact resistance	150 µΩ
Contact material	brass, silver plated
Insulation coordination	6 kV/2 ³⁾
Insulation material/Flame rating	PC/UL94-V0
Withdrawal force	25 N
Maximum temperature rise	49 K (UL 1977 – Section 16)
Temperature range	-40 °C...+125 °C

*) Long version = 26/short = 23
 R = Raster dimension
 1) Includes 400 V/690 V (IEC 60038)
 2) See page 44: UL Engineering considerations
 3) Valid between live parts and mounting surface

Maximum mounting offset

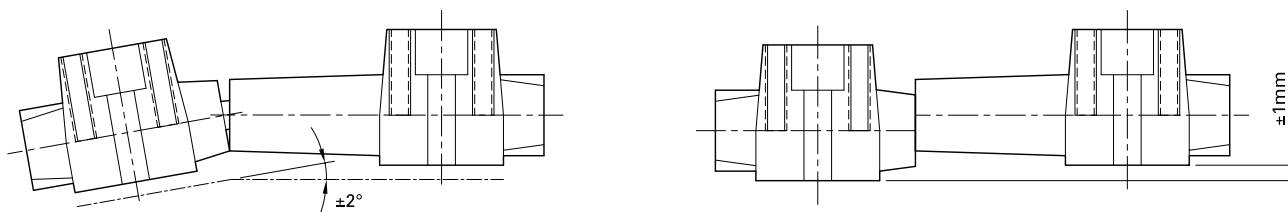

No.	Order No.	Type	Description	UL Approval	Delivered
1	15.0152	P1/100-BS	Socket	UL ¹⁾	assembled

Individual parts

3	01.0405	B6-P1/100-S	Socket
4	15.5252	I-P1/100-B	Insulation, black
5	15.5253	GS-P1/100	Grub screw, M6×12

2	15.0150	P1/100-SSK	Plug	UL ¹⁾	assembled
2	15.0151	P1/100-SSL ²⁾	Plug		assembled

Individual parts

6	04.0401	SP6-P1/100-SK	Plug
7	04.0402	SP6-P1/100-SL	Plug, leading pin
8	15.5251	I-P1/100-S	Insulation, black
5	15.5253	GS-P1/100	Grub screw, M6×12

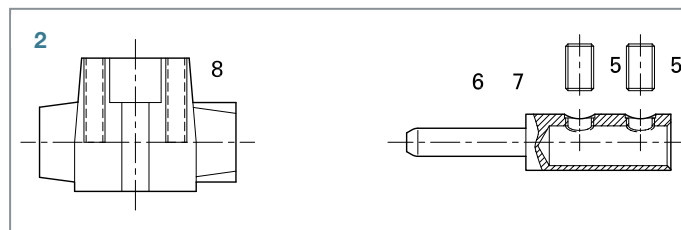
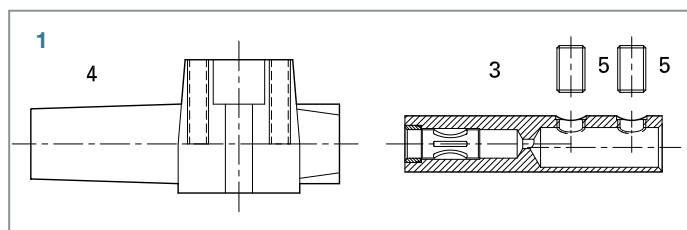

¹⁾ See page 42: UL Engineering considerations

²⁾ With leading pin

SLIDE-IN SOCKETS AND PLUGS

Slide-in sockets EBB...
Slide-in plugs EBS...

EBB8-V0
EBB10-V0



EBB14-V0



EBS8-V0
EBS10-V0



EBS14-V0



Drilling plan
EBB8-V0, EBS8-V0
EBB10-V0, EBS10-V0

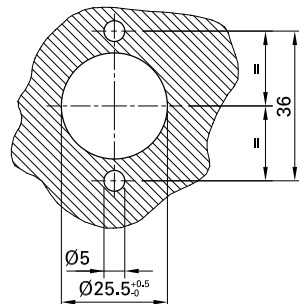

Drilling plan
EBB14-V0, EBS14-V0

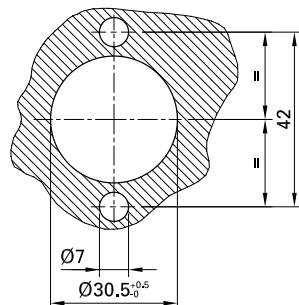

Technical data

Rated voltage	500 V
Test voltage (50 Hz, 1 min.)	3.3 kV
Flashover voltage (50 Hz)	> 4 kV
Insulation coordination	6 kV/2
Insulation material	EB...8.../EB...10..., PA66 ¹⁾ EB...14..., PA66 ²⁾



Assembly instructions MA020

www.staubli.com/electrical

Order No.	Type	Threaded bolt connection	Conductor cross section Cu	Nominal-Ø pin/socket	Withdrawal force	Max. tightening torque ³⁾	Rated current	Contact resistance	Short-circuit current (1 s)	Short-circuit current (3 s)
			mm ²	mm	N	Nm	A	µΩ	kA	kA
01.0474	EBB8-V0	M8	35	8	20	6	160	60	3	1,5
04.0427	EBS8-V0	M8	35	8	-	6	160	-	3	1,5
01.0475	EBB10-V0	M10	50	10	30	10	200	50	5,5	3
04.0428	EBS10-V0	M10	50	10	-	10	200	-	5,5	3
01.0431	EBB14-V0	M16	120	14	50	22	300	50	12	8
04.0431	EBS14-V0	M16	120	14	-	22	300	-	12	8

Ordering information and individual parts, see pages 20 – 22.

¹⁾ Colour black

²⁾ Colour red

³⁾ Of the cable connection nut

Order No.	Type	Dimensions (mm)													
		A	B	C	D	E	F	G	H	I	J	K	L	M	N
01.0474	EBB8-V0	85	8	9	5	50	26	25	M8	15	32	47	36	8,5	4,7
04.0427	EBS8-V0	80	8	9	5	12	26	25	M8	15	32	47	36	8,5	4,7
01.0475	EBB10-V0	90	10	9	5	50	31	25	M10	16	32	47	36	8,5	4,7
04.0428	EBB10-V0	85	10	9	5	12	31	25	M10	16	32	47	36	8,5	4,7
01.0431	EBB14-V0	120,5	14	12	7	53	55,5	30	M16	24	40	60	42	11	7
04.0431	EBS14-V0	132,5	14	12	7	20	55,5	30	M16	24	40	60	42	11	7

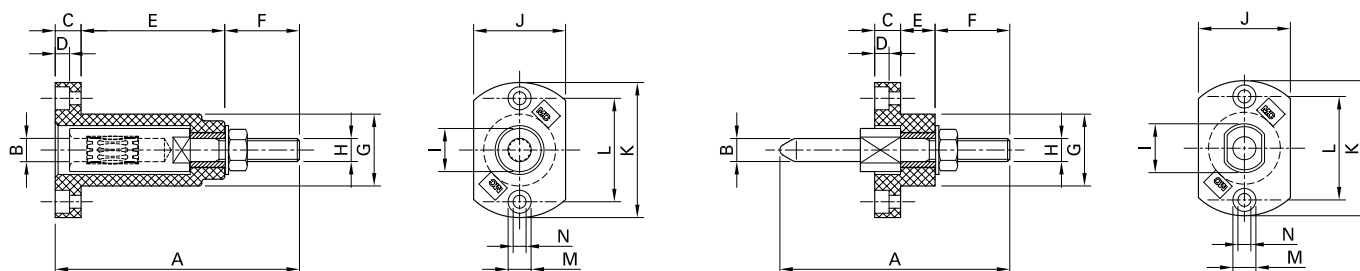
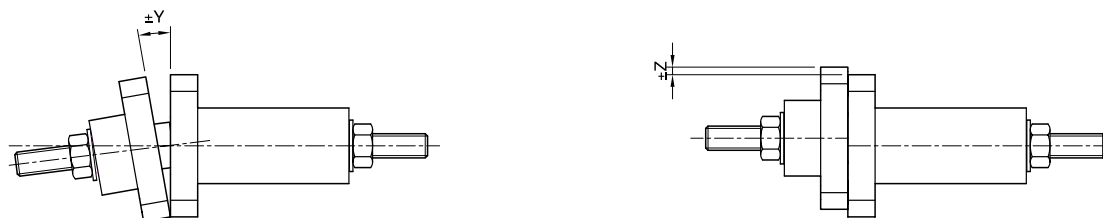
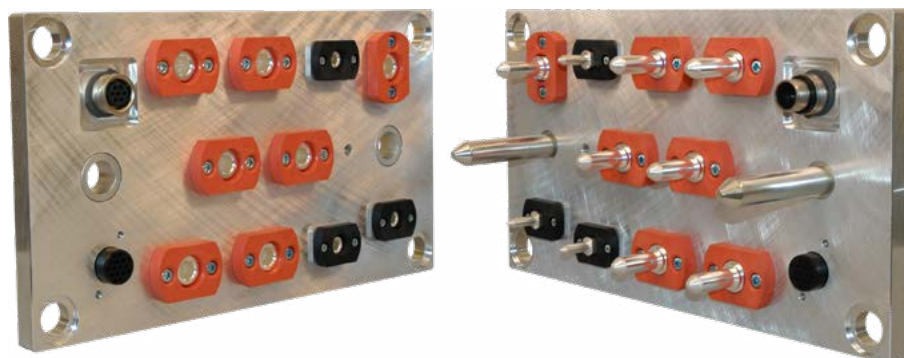

Plate spacing = 2 x C

Maximum mounting offset



Type	Y	Z	Max. panel thickness	Min. distance between 2 elements
EBB8.../EBS8...	2.5°	± 1 mm	5 mm	35 mm
EBB10.../EBS10...	1.5°	± 1 mm	5 mm	35 mm
EBB14.../EBS14...	1°	± 1 mm	10 mm	45 mm



Application with slide-in sockets and plugs on a docking plate

No.	Order No.	Type	Ø mm	Description	Delivered
	01.0474	EBB8-V0	8	Socket	assembled
	01.0475	EBB10-V0	10	Socket	assembled
	01.0431	EBB14-V0	14	Socket	assembled

Individual parts

1	01.0411	B-EBB8	8	Socket insert, brass, silver-plat.
1	01.0419	B-EBB10	10	Socket insert, brass, silver-plat.
1	01.0470	B-EBB14	14	Socket insert, brass, silver-plat.
2	01.0413	D-EBB/S8	8	Spacer tube ¹⁾
2	01.0418	D-EBB/S10	10	Spacer tube ¹⁾
3	01.0466	I-EBB8-V0	8+10	Insulation PA66, black
3	01.0471	I-EBB14-V0	14	Insulation PA66, red
4	08.0721	FS/M8	8	Lock washer DIN137, bronze
4	08.0722	FS/M10	10	Lock washer DIN137, bronze
4	08.0309	U/M16	14	Washer
5	08.0005	MU0,5D/M8	8	Hex. nut M8
5	08.0006	MU0,5D/M10	10	Hex. nut M10
5	08.0009	MU0,5D/M16	14	Hex. nut M16

	04.0427	EBS8-V0	8	Plug	assembled
	04.0428	EBS10-V0	10	Plug	assembled
	04.0431	EBS14-V0	14	Plug	assembled

Individual parts

8	04.0411	S-EBS8	8	Plug insert, brass, silver-plat.
8	04.0417	S-EBS10	10	Plug insert, brass, silver-plat.
8	04.0432	S-EBS14	14	Plug insert, brass, silver-plat.
9	01.0413	D-EBB/S8	8	Spacer tube ¹⁾
9	01.0418	D-EBB/S10	10	Spacer tube ¹⁾
10	04.0435	I-EBS8-V0	8+10	Insulation PA66, black
10	04.0433	I-EBS14-V0	14	Insulation PA66, red
4	08.0721	FS/M8	8	Lock washer DIN137, bronze
4	08.0722	FS/M10	10	Lock washer DIN137, bronze
4	08.0309	U/M16	14	Washer
5	08.0005	MU0,5D/M8	8	Hex. nut M8
5	08.0006	MU0,5D/M10	10	Hex. nut M10
5	08.0009	MU0,5D/M16	14	Hex. nut M16

¹⁾ Only with EBB8-V0, EBB10-V0, EBS8-V0, EBS10-V0

Cable fixing material (please order separately)

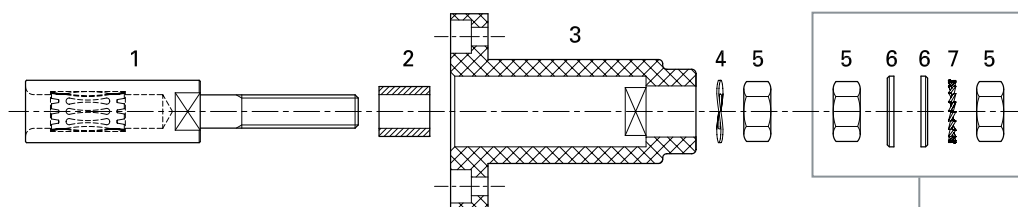

Cable fixing material
please order separately

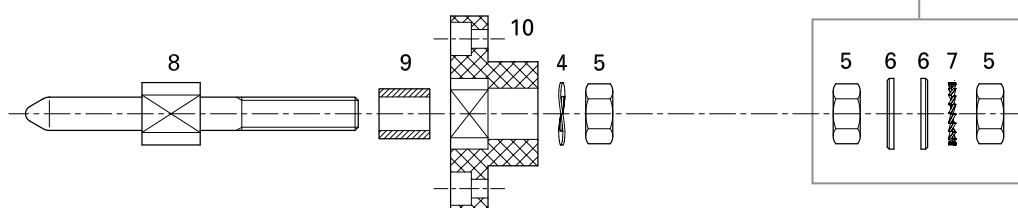

No.	Order No.	Type	Ø mm	Description
5	08.0005	MU0,5D/M8	8	Hex. nut M8
6	08.0305	U/M8	8	Washer, brass, silver-plated
7	08.0705	F/M8	8	Serrated lock washer
5	08.0006	MU0,5D/M10	10	Hex. nut M10
6	08.0306	U/M10	10	Washer, brass, silver-plated
7	08.0706	F/M10	10	Serrated lock washer
5	08.0009	MU0,5D/M16	14	Hex. nut M16
6	08.0309	U/M16	14	Washer, brass, silver-plated
7	08.0709	F/M16	14	Serrated lock washer

FORK PLUGS GSR5/...

Introduction

- Rated current up to 1490 A
- Rated voltage up to 600 V
- Standard units or specially designed plugs according to your requirements

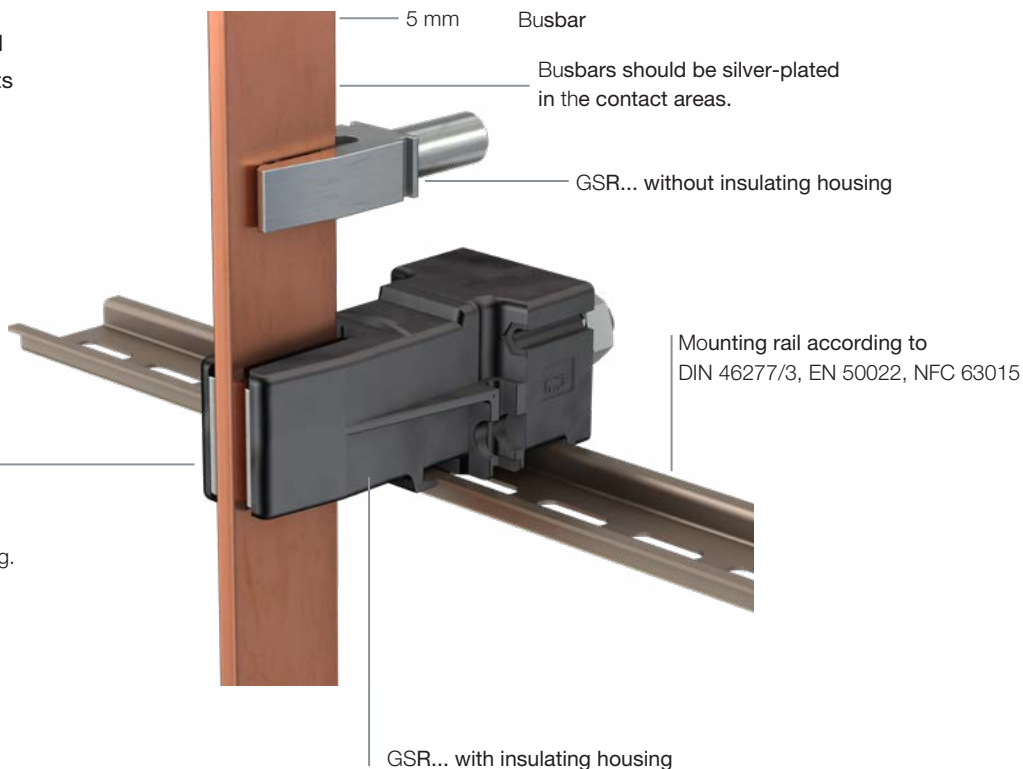

The GSR... fork connectors are suitable for applications in noncorrosive atmospheres, e.g. indoors or in protected outdoor installations.

Securing clip holding the GSR... in a floating support.

Stäubli MULTILAM LAI, silver-plated

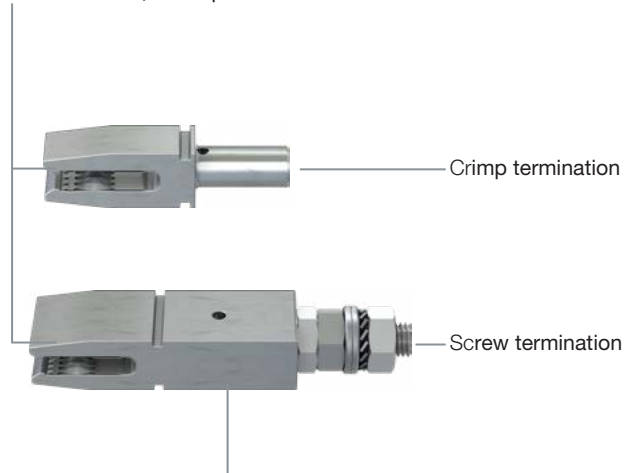

Material: Aluminium, silver-plated

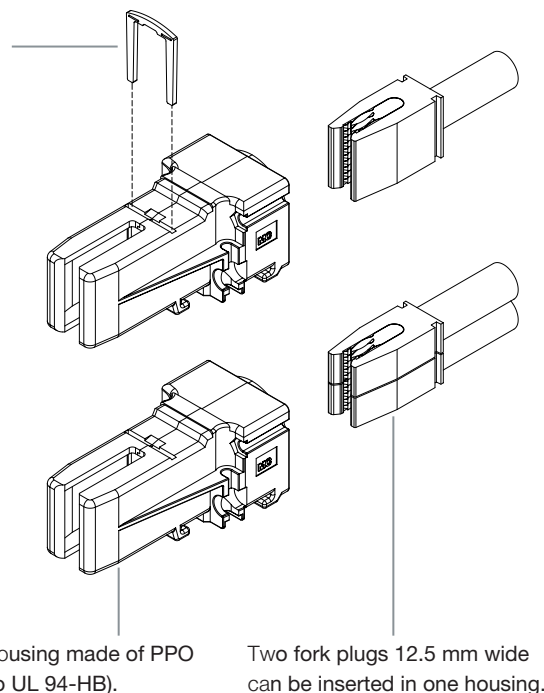

Fork plug G-GSR5/...

With crimp termination

G-GSR5/...

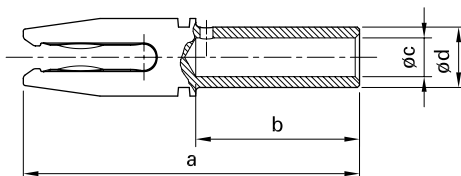

Technical data

Rated voltage	600 V ¹⁾
Test voltage (50 Hz, 1 min.)	3.5 kV ¹⁾
Insulation coordination	6 kV/3 ¹⁾
Material	Al, silver-plated

Order No.	Type	Conductor cross section mm ²	Sizes (mm)					Insertion force ²⁾ N	Withdrawal force ²⁾ N	Rated current ³⁾ A	Rated peak withstand current kA	Short-circuit current (1 s) kA	Short-circuit current (3 s) kA
			a	b	Ø c	Ø d	e						
10.5005	G-GSR5/10	10	55	15	5	10	12.5	24	20	80	5.5	1	0.6
10.5006	G-GSR5/16	16	65	25	6	11	12.5	24	20	100	8.5	1.5	1
10.5007	G-GSR5/25	25	65	25	6.7	12	12.5	24	20	130	14.0	2.5	1.5
10.5008	G-GSR5/35	35	78	38	9	14	25	48	40	160	19.5	3.5	2
10.5009	G-GSR5/50	50	78	38	11	16	25	48	40	200	28	5	3
10.5010	G-GSR5/70	70	78	38	12.5	18	25	48	40	250	42	7.5	4



Suitable insulating housing I-GSR5 with securing clip S-GSR5, see page 27

¹⁾ Only valid between fork plug in the insulating housing and the standard mounting rail

²⁾ Typical ratings, measured with silver plated copper busbars

³⁾ See derating diagrams, pages 38 – 40

Fork plug G-GSR5/B-M10x50

With screw termination

G-GSR5/B-M10x50

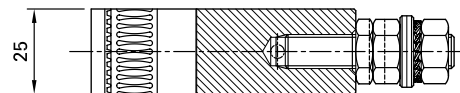
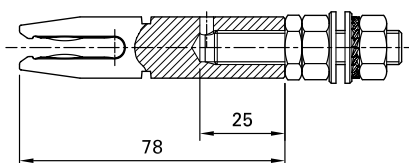

Technical data

Rated voltage	600 V ¹⁾
Test voltage (50 Hz, 1 min.)	3.5 kV ¹⁾
Insulation coordination	6 kV/3 ¹⁾
Insertion force	48 N ²⁾
Withdrawal force	40 N ²⁾
Current carrying capacity and terminations	see page 28

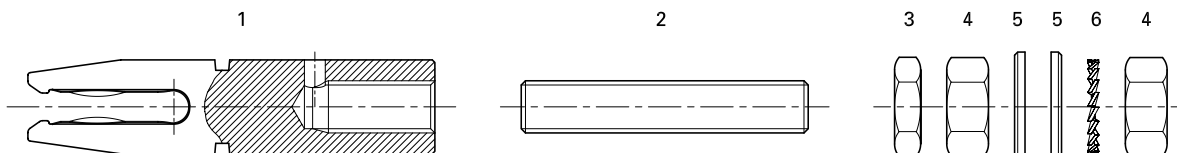

Pos.	Order No.	Type	Description
1-6	10.5012	G-GSR5/B-M10x50	Fork plug with screw termination, complete

Individual parts

1	10.5011	G-GSR5/M10	Fork plug with internal thread M10
2	10.5023	B-GSR	Threaded bolt
3	08.0006	MU0,5D/M10 AG	Fastening nut
4	08.0106	MU0,8D/M10	Termination nut
5	08.0306	U/M10 AG	Washer
6	08.0716	F/M10 DIN6798A BN91220	Serrated lock washer



Suitable insulating housing I-GSR5 with securing clip S-GSR5, see page 27

¹⁾ Only valid between fork plug in the insulating housing and the standard mounting rail

²⁾ Typical ratings, measured with silver plated copper busbars

Insulating housing I-GSR5

For fork plugs G-GSR5/...

I-GSR5

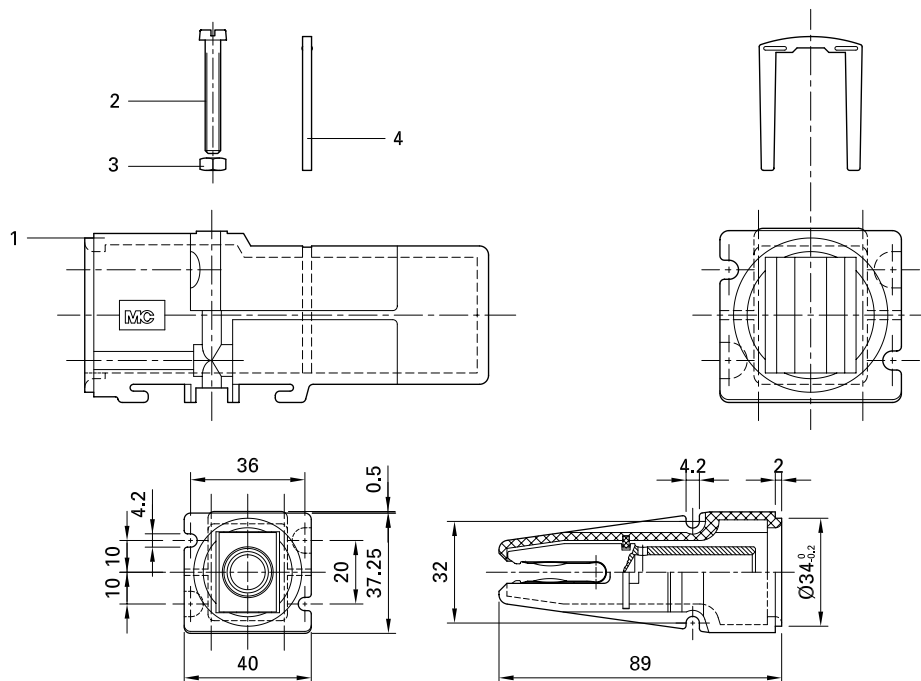

Technical data

Test voltage (50 Hz, 1 min.)	3.5 kV ¹⁾
Insulation coordination	6 kV/3 ¹⁾
Insulation	PPO
Tightening torque/Fixing screws	max. 1.3 Nm

Maximum mounting offset

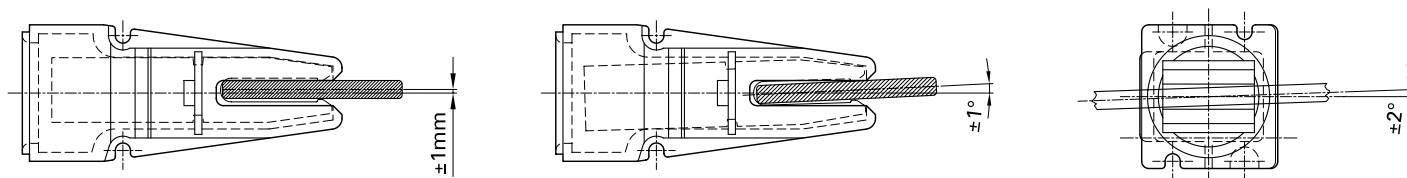

Pos.	Order No.	Type	Description
1	10.5020	I-GSR5	Insulating housing for fork plugs G-GSR5/...
2	10.5022	SCH-GSR5	Cheese headed screw M4x25
3	10.5024	MU-GSR5	Hex. nut M4
4	10.5021	S-GSR5	Securing clip for fork plug G-GSR5/...

¹⁾ Only valid between fork plug in the insulating housing and the standard mounting rail

Terminations and current carrying capacity

For fork plug G-GSR5/B-M10x50

Cu-Busbar

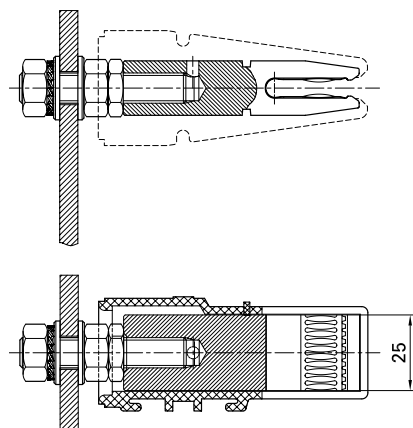

Cable lug

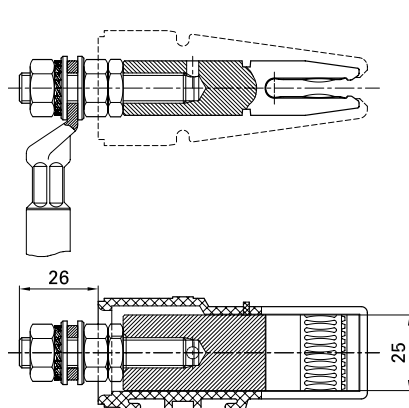

Cu stranded ribbon cable

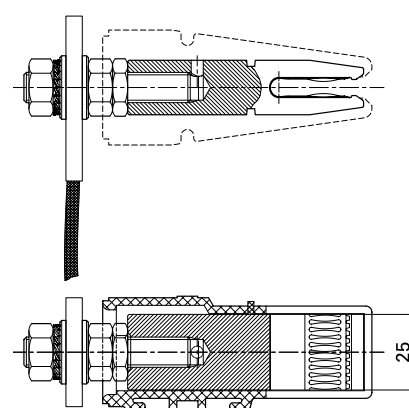

Conductor cross section Cu	Rated current	Rated peak withstand current	Short-circuit current (1 s)	Short-circuit current (3 s)
mm ²	A	kA	kA	kA
15x5	200	27	7	5.2
20x5	260	27	7	5.2
25x5	280	27	7	5.2
30x5	350	54	12	10
40x5	400	54	12	10
50x5	400	54	12	10
60x5	400	54	12	10
80x5	400	54	12	10

Cable lug type		Conductor cross section Cu	Rated current ¹⁾	Rated peak withstand current	Short-circuit current (1 s)	Short-circuit current (3 s)
²⁾	³⁾	mm ²	A	kA	kA	kA
10	10	10	80	5.5	1	0.6
16	10	16	100	8.5	1.5	1
25	10	25	130	14	2.5	1.5
35	10	35	160	19.5	3.5	2
50	10	50	200	28	5	3
70	10	70	250	42.5	7.5	4
95	10	95	300	54	10	6

Conductor cross section Cu	Rated current	Rated peak withstand current	Short-circuit current (1 s)	Short-circuit current (3 s)
mm ²	A	kA	kA	kA
10	80	5.5	1	0.6
16	110	8.5	1.5	1
25	140	14.5	2.5	1.5
35	180	19.5	3.5	2
50	220	28	5	3
70	275	42.5	7.5	4
95	330	54	10	6
120	400	54	12	9

¹⁾ See derating diagram, page 39

²⁾ Conductor cross section

³⁾ Drill hole

For further information about fork plug assembly, see page 42

Busbar according to DIN EN 13601 Copper or copper alloy

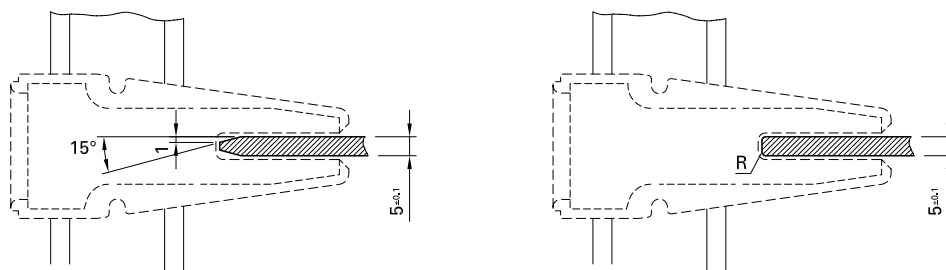

Arrangement and fastening for fork plugs GSR5/...

Direct on foundation

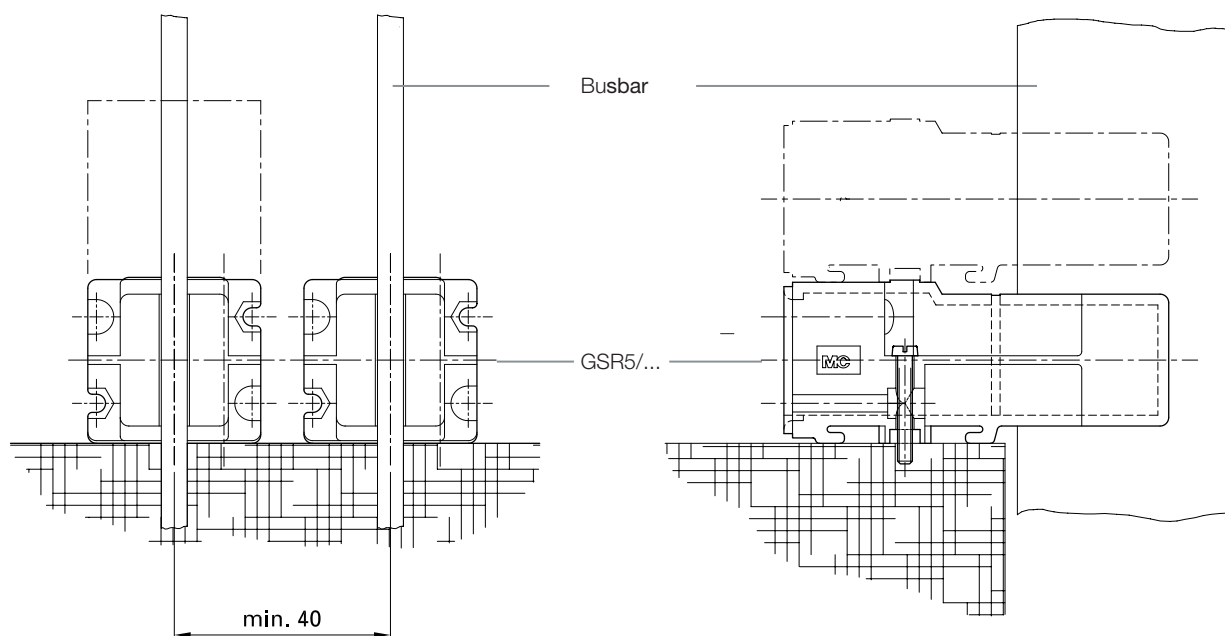

On panel according to customer's assembly drawing

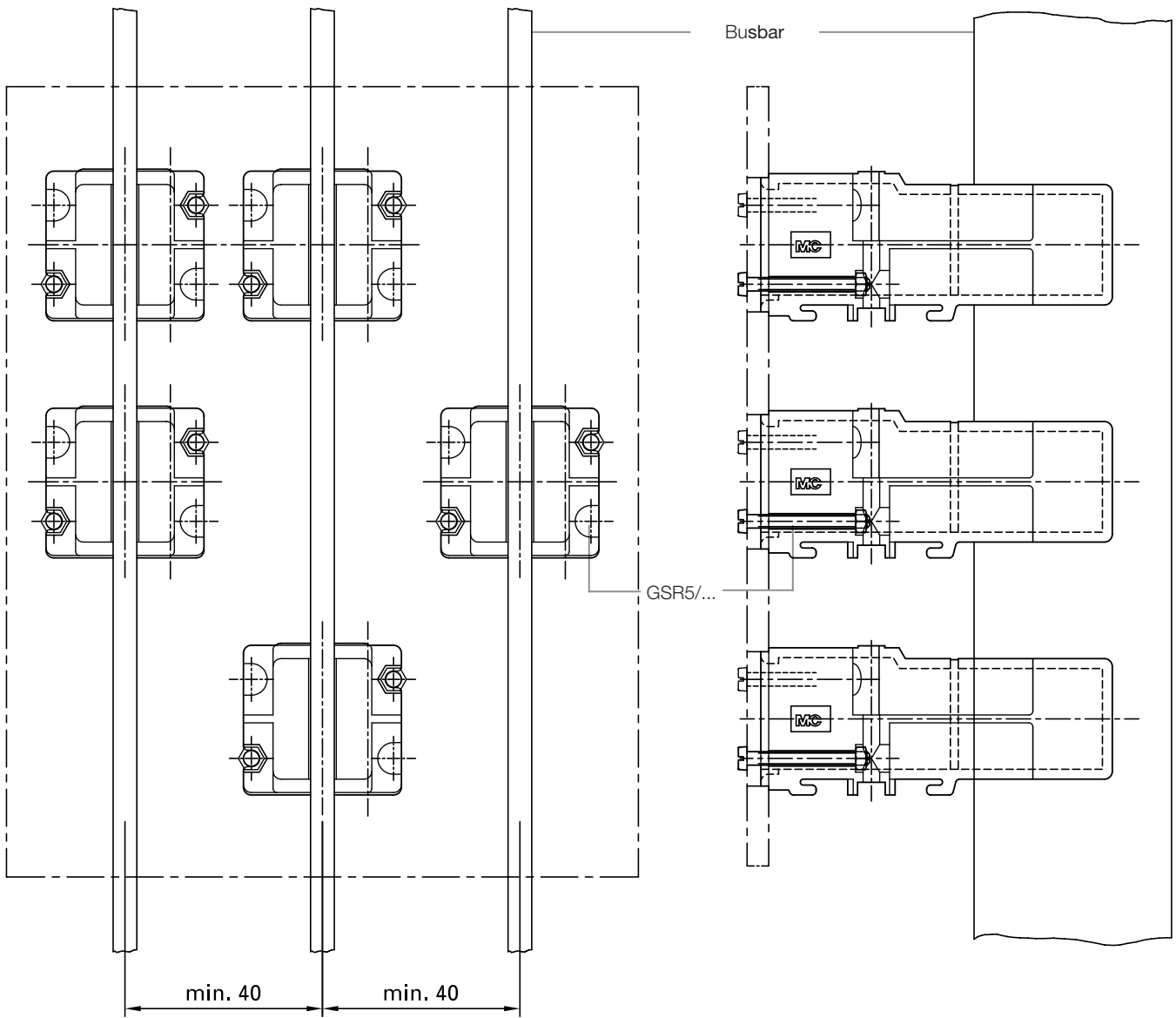

On hat rails according to DIN 46277/3,
EN50022, NFC 63015

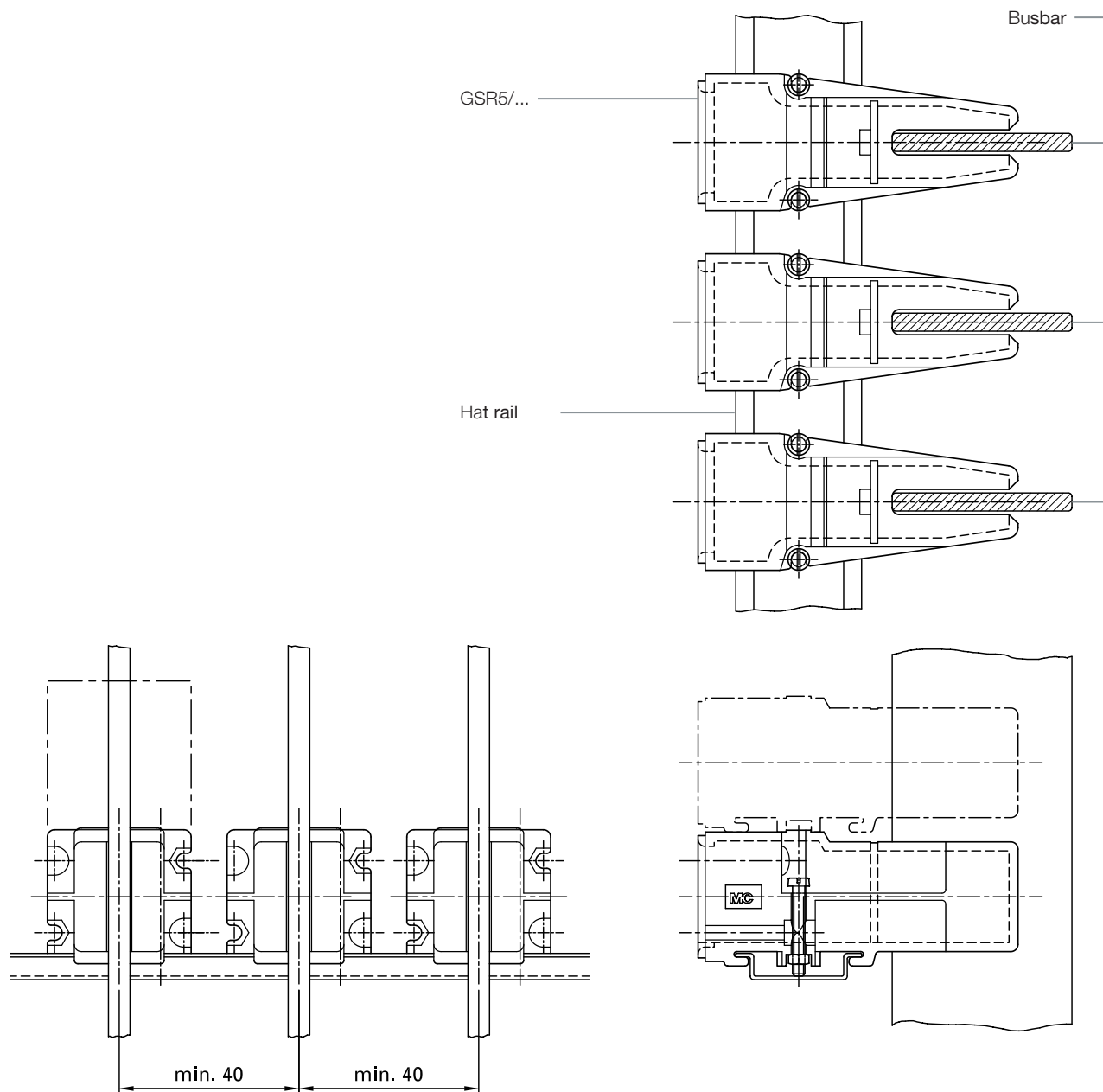

For further information about fork plug
assembly, see page 42

DOUBLE FORK PLUGS GSRD...

Introduction

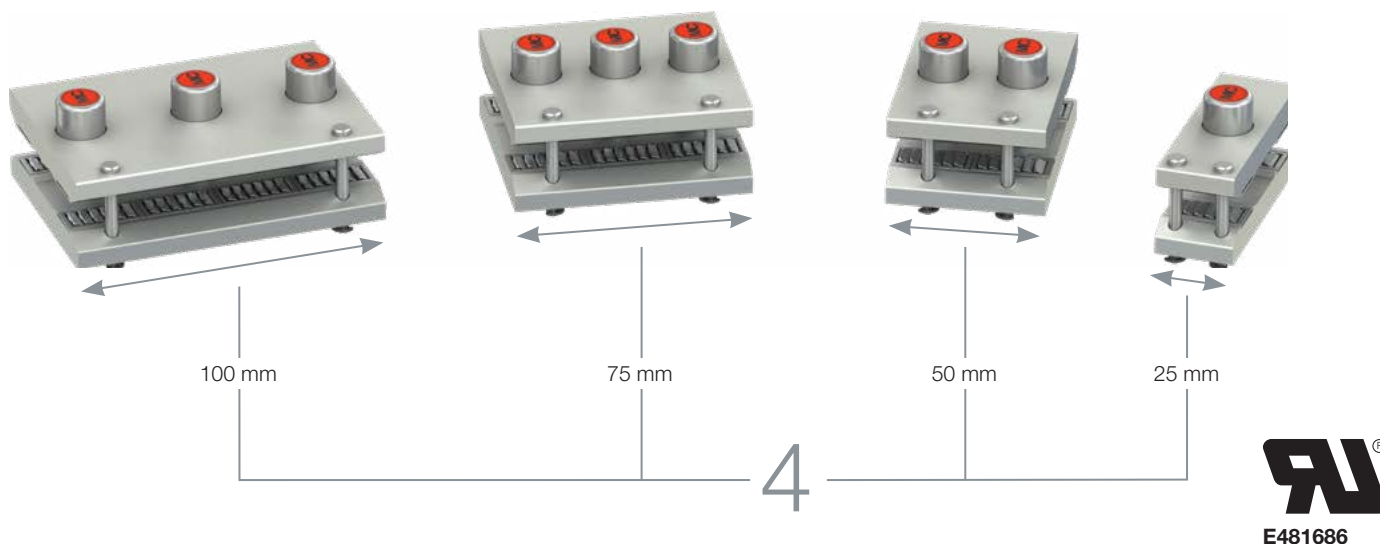

Standard versions¹⁾

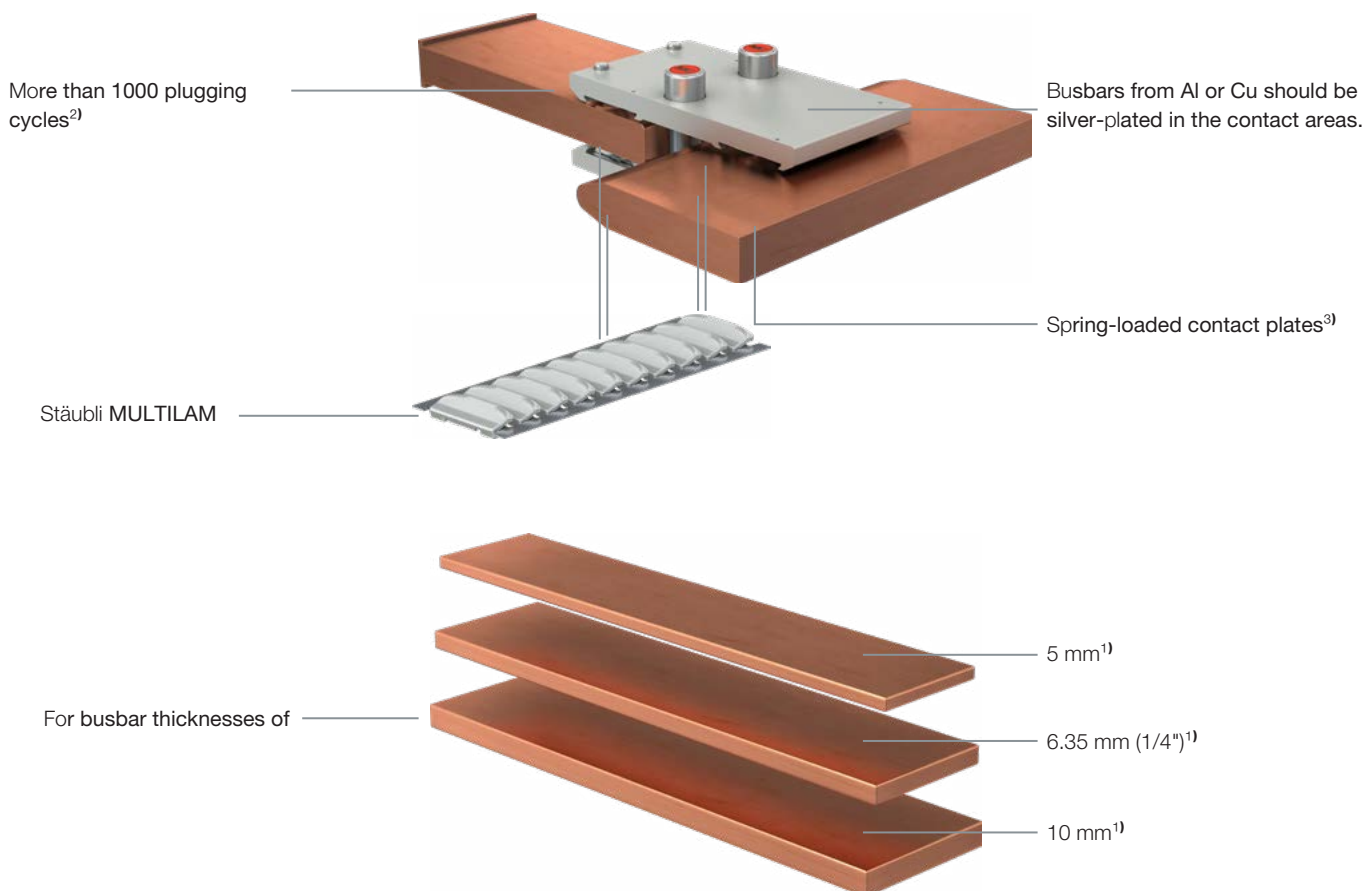

¹⁾ Special double fork plugs can be supplied in non-standard widths and thicknesses on request

²⁾ With slightly greased busbars. Lubricants see page 42

³⁾ Aluminium, silver plated

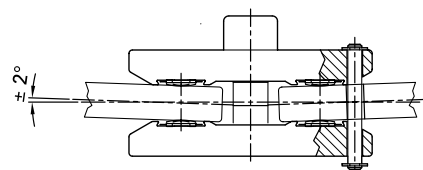
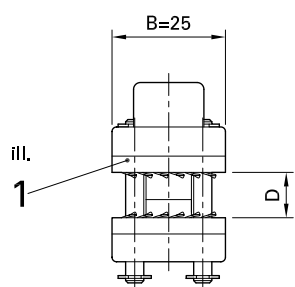

Angular tolerance

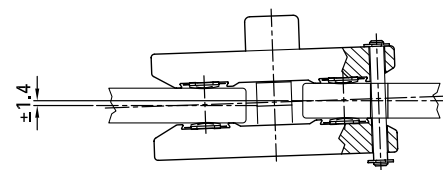

Alignment tolerance

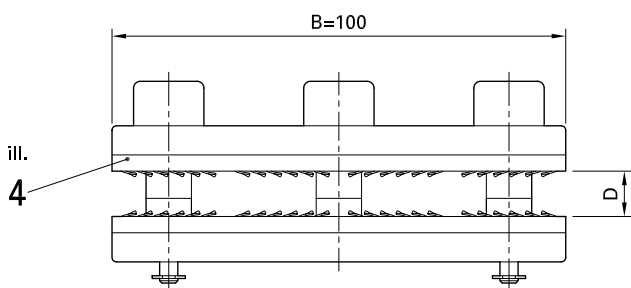
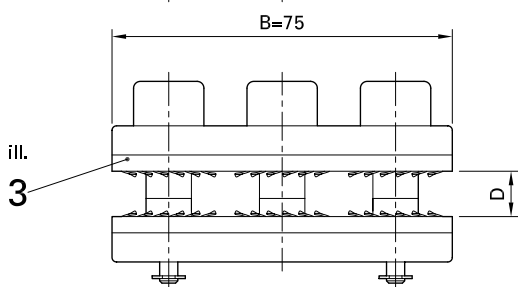
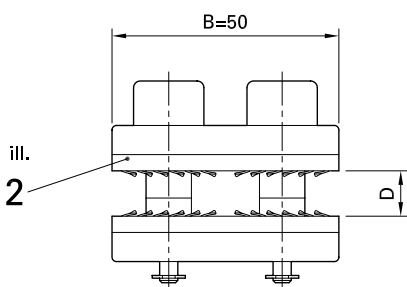

Drilling plan

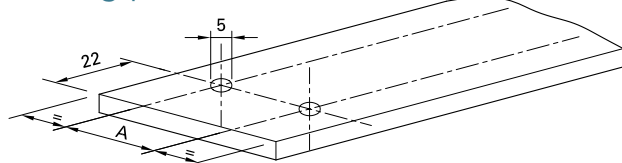

Type	Sizes (mm)
GSRD...25	A
GSRD...50	25
GSRD...75	50
GSRD...100	75

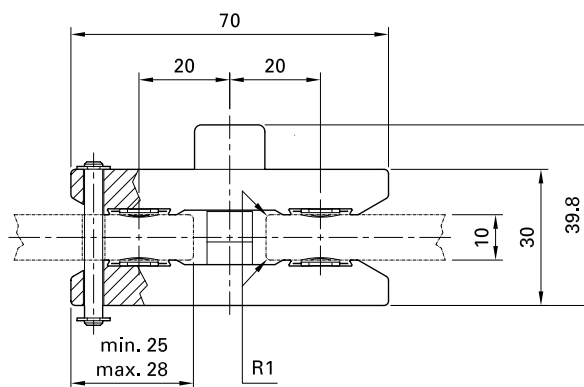

Application example

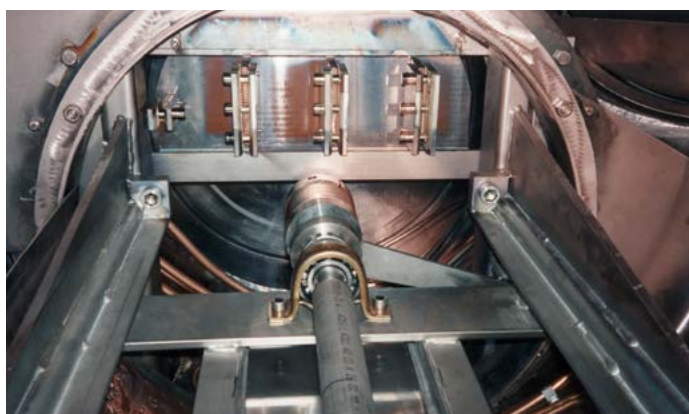

Connection between the busbars of a vaporizer (not visible in the illustration) and the high-current feed through of a vacuum cylinder with double fork plugs.

Technical data and ordering information

Ill.	Order No.	Type	for thickness of busbar D	Fork plug width B	Insertion force	Withdrawal force	Contact resistance ¹⁾	Rated current ²⁾ Cu ³⁾	Rated current ²⁾ Al ⁴⁾	Short-circuit current Cu ³⁾	Short-circuit current Cu ³⁾	Short-circuit current Al ⁴⁾	Short-circuit current Al ⁴⁾	Rated peak withstand current
			mm	mm	N	N	μΩ	A	A	kA (1s)	kA (3s)	kA (1s)	kA (3s)	kA
1	10.0031	GSRD5-25	5	25	80	40	40	325	255	9.5	7.5	9.5	6.5	36
2	10.0032	GSRD5-50	5	50	160	80	20	580	455	19	15.5	19	13	72
3	10.0033	GSRD5-75	5	75	240	120	13.5	885	685	28.5	23.5	28.5	20.8	108
4	10.0034	GSRD5-100	5	100	320	160	10	1080	845	38	31.3	38	26	144

1	10.0035	GSRD6/6,35-25	6 – 6.35	25	80	40	40	385	285	9.5	7.5	9.5	7.5	36
2	10.0036	GSRD6/6,35-50	6 – 6.35	50	160	80	20	645	505	19	15.5	19	15.5	72
3	10.0037	GSRD6/6,35-75	6 – 6.35	75	240	120	13.5	965	760	28.5	23.5	28.5	23.5	108
4	10.0038	GSRD6/6,35-100	6 – 6.35	100	320	160	10	1170	920	38	31.5	38	31.2	144

1	10.0039	GSRD10-25	10	25	80	40	40	480	375	9.5	7.5	9.5	7.5	36
2	10.0040	GSRD10-50	10	50	160	80	20	850	665	19	15.5	19	15.5	72
3	10.0041	GSRD10-75	10	75	240	120	13.5	1240	980	28.5	23.5	28.5	23.5	108
4	10.0042	GSRD10-100	10	100	320	160	10	1490	1190	38	31.5	31.5	31.5	144

Application example

Connection between fixed and movable busbars.

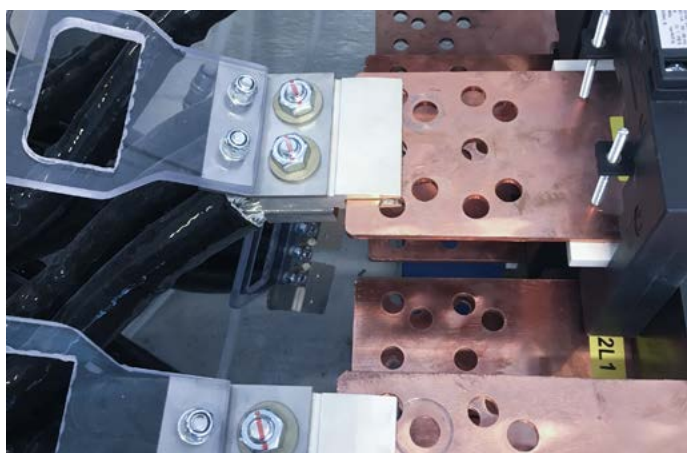

¹⁾ Data valid with silver plated contact areas on copper and aluminium busbars

²⁾ Rated current according to standard DIN 43671, see derating diagrams, page 40

³⁾ Data valid for copper busbars

⁴⁾ Data valid for aluminium busbars

STÄUBLI SPECIAL FORK PLUGS

Overview



Fork plugs are cut from section rods and after further machining they are as a rule silver-plated and then fitted with an Stäubli MULTI-LAM. This allows fork plugs to be made in any desired width.

In the terminal part of the plug, all types of lead attachment are possible within the limits of the section dimensions, e.g. screw or crimp connection, slots, drilled holes, screw threads etc.

See pages 37 and 38 for some examples of special versions for which tools for the manufacture and supply of fork plugs already exist (not in stock).

Various termination and fixing possibilities

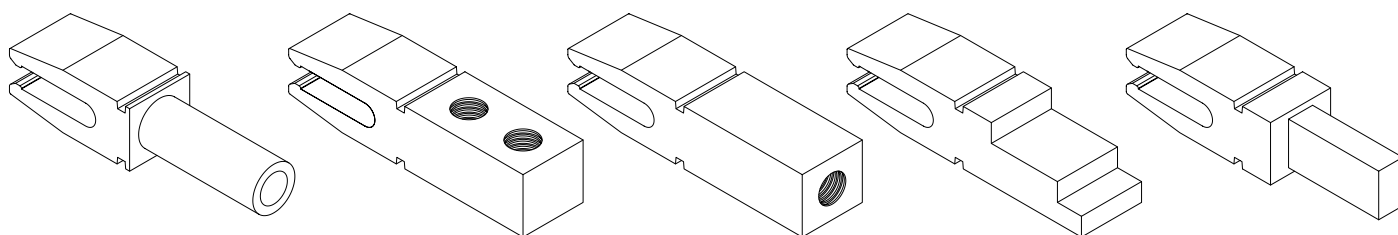

Stäubli has many years of experience with fork plugs, and is the ideal address for such contact systems. Ask us, our designers and engineers will be pleased to advise you.

Examples of special versions of fork plugs

Profile drawing	Reference	Rated size = Size of the busbar	Typ of MULTILAM®	Rated current per 10 mm busbar length	Connection system	Material of profile
	P-GSR2 11000443	1.57 – 2 mm ¹⁾ 2 mm ²⁾	LA spez. LAIII/0,2	≈ 100 A	S ³⁾ + C ³⁾	CuZn
	P-GSR2-D 11000437	1.57 – 2 mm ¹⁾ 2 mm ²⁾	LA spez. LAIII/0,2	≈ 100 A	–	CuZn
	P-GSR1.57 11000438	1.57 – 2 mm ¹⁾ 2 mm ²⁾	LA spez. LAIII/0,2	≈ 100 A	–	Al
	P-GSR2-W 11000441	1.57 – 2 mm ¹⁾ 2 mm ²⁾	LA spez. LAIII/0,2	≈ 100 A	S ³⁾	CuZn
	P-GSR3 3W7.131.00	3 mm ²⁾	LAIII/0,2	≈ 100 A	S ³⁾	CuZn

¹⁾ With special MULTILAM LA spec.

²⁾ Corresponds to busbar thickness according to DIN 46433 or ±0.1 mm.

³⁾ C = Crimp connection
S = Screw connection

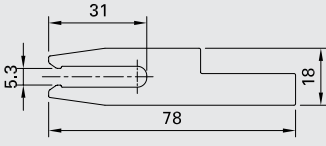
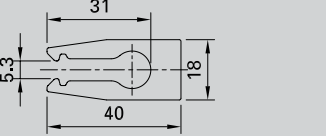
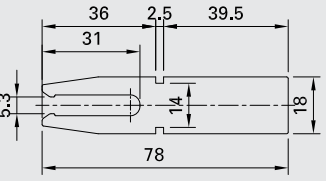
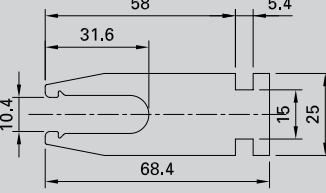
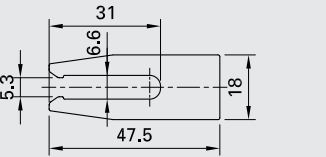
Profile drawing	Reference	Rated size = Size of the busbar	Type of MULTILAM®	Rated current per 10 mm busbar length	Connection system	Material of profile
	P-GSR5 11003537	5 mm ²⁾	LAI/0,2	≈ 200 A	S ³⁾	CuZn
	P-GSR5 11003524	5 mm ²⁾	LAI/0,2	≈ 200 A	S ³⁾	CuZn
	P-GSR5N 10.5309	5 mm ²⁾	LAI/0,2	≈ 200 A	S ³⁾ + C ³⁾	Al
	P-GSR10 3W7.089.00	10 mm ²⁾	LAI/0,2	≈ 200 A	S ³⁾	Al
	P-GSR5 11006003	5 mm ²⁾	LAI/0,2	≈ 200 A	S ³⁾	CuZn

¹⁾ With special MULTILAM LA spec.

²⁾ Corresponds to busbar thickness according to DIN 46433 or ±0.1 mm.

³⁾ C = Crimp connection
S = Screw connection

ANNEXE

Derating diagrams

Examples of 2 and 6 current-carrying conductors (bundled) according to DIN VDE 0298, part 4 for 1.5 mm², 2.5 mm², 10 mm²,

16 mm² und 25 mm² Cu wire, PVC insulated for higher temperatures (90 °C).

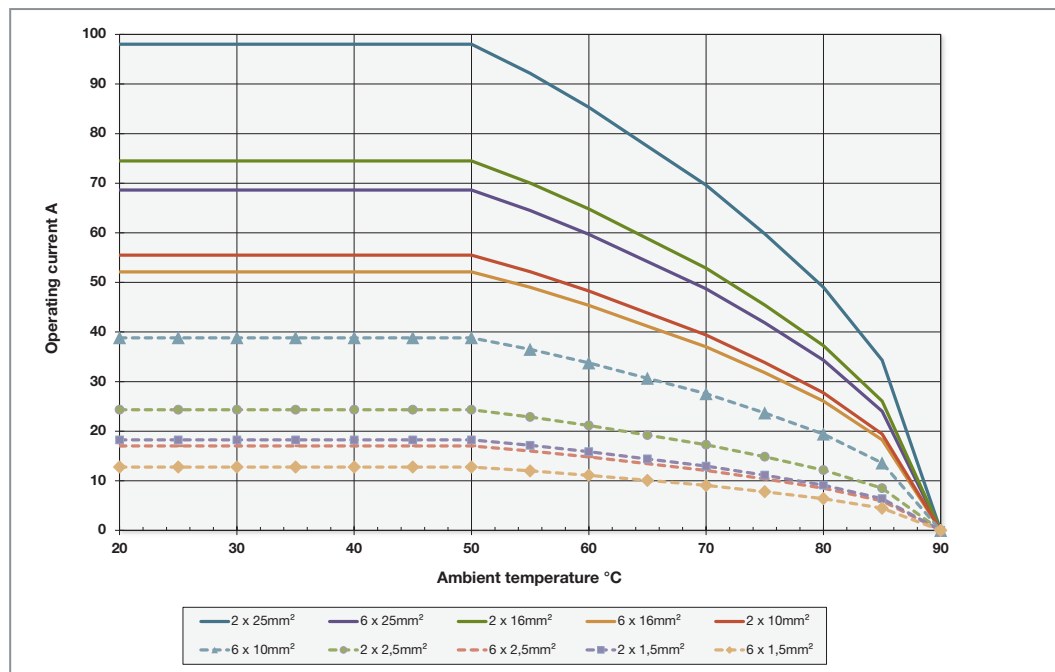

Rectangular section copper busbars according to DIN 43671. Possibility to contact

with fork plugs GSR5/... with crimp or cable lug termination.

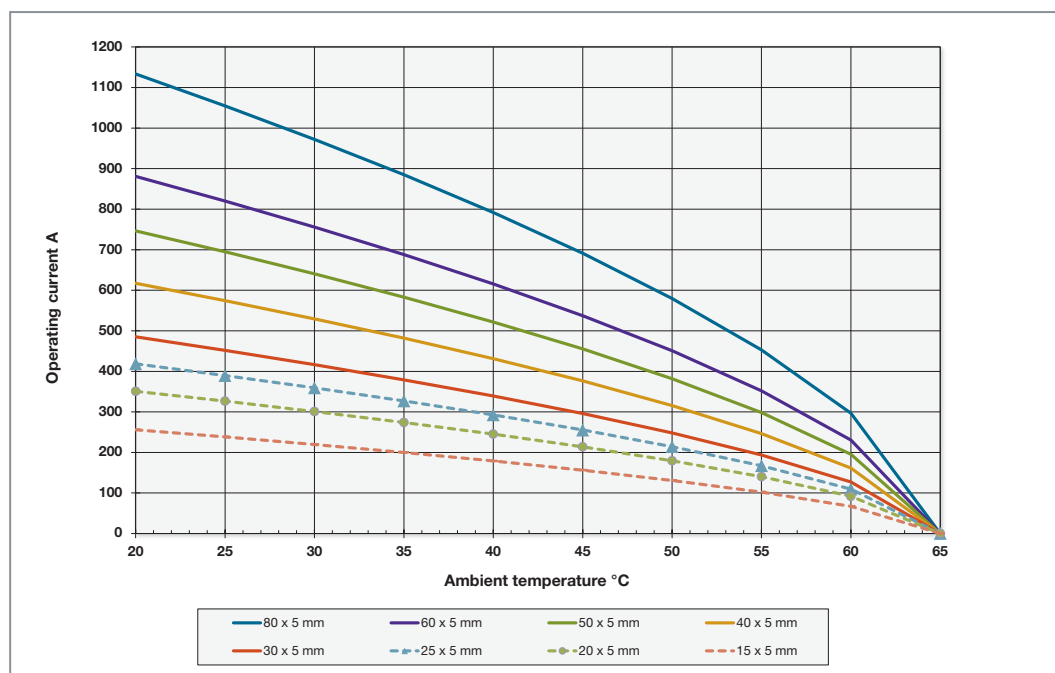

PVC insulated Cu conductors 10 mm²-95 mm², (type 70 °C) free in air, according to DIN VDE 0298, part 4. Possibility to contact with fork plugs GSR5/... with crimp or cable lug termination.

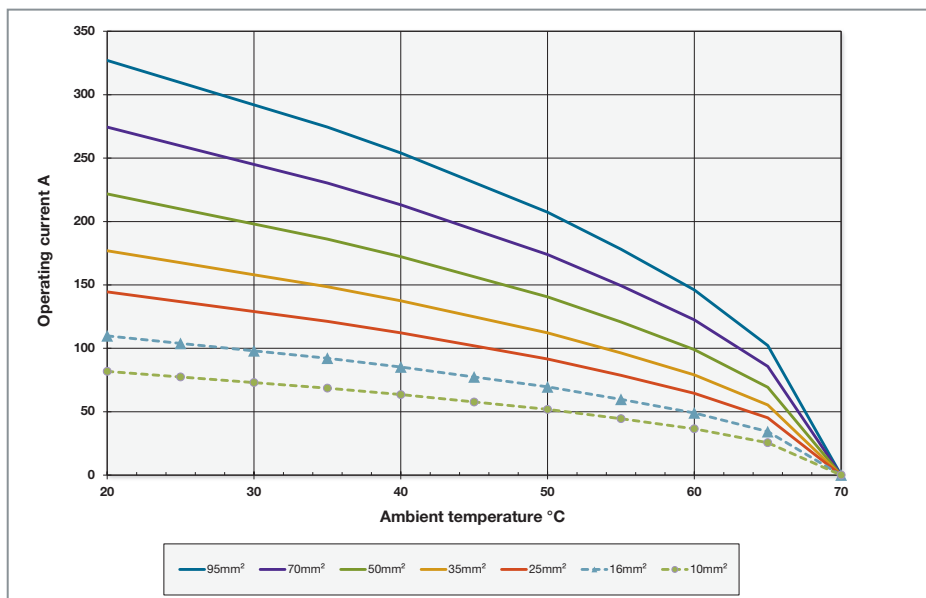

Derating diagrams

Rectangular section copper busbars acc. to DIN 43671. Possibility to contact with fork plugs GSRD...

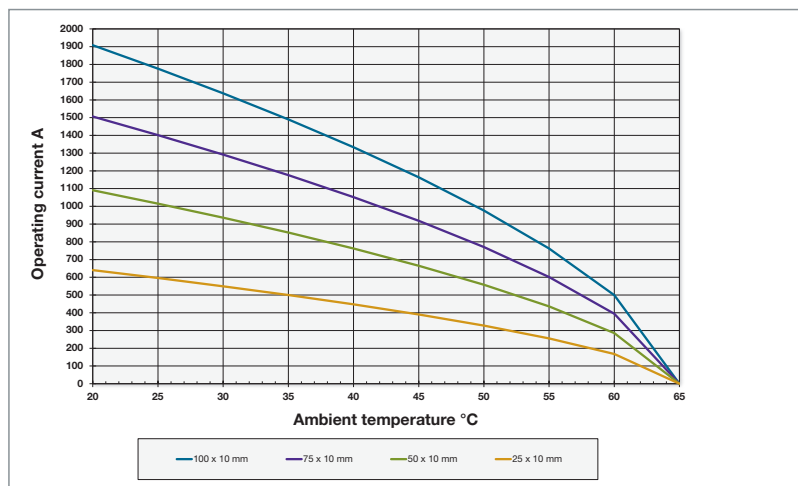
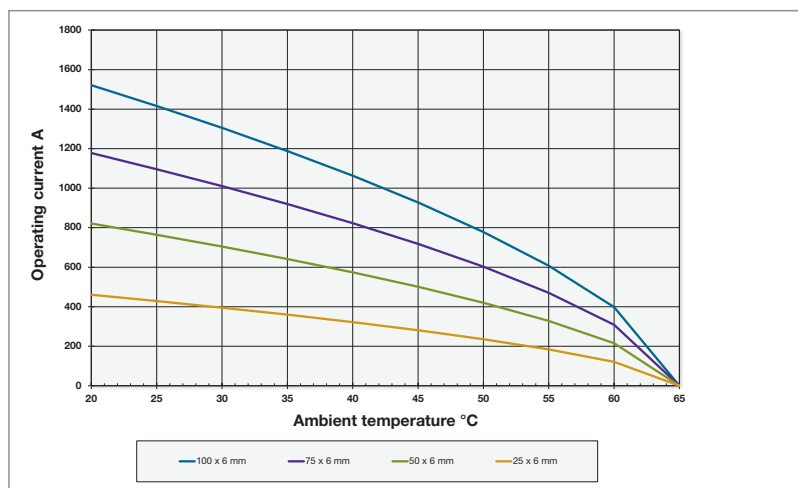
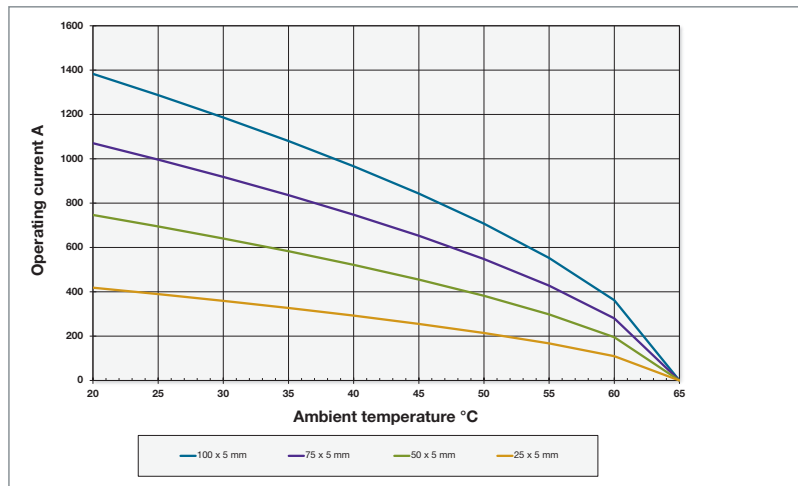

UNLIMITED POSSIBILITIES FOR CONTACT SOLUTIONS

MULTILAM Technology



MULTILAM are specially formed and resilient contact elements. All Stäubli Electrical Connectors products benefit from the unique and outstanding performance of the MULTILAM Technology.

Thanks to their constant spring pressure, MULTILAM louvers ensure continuous contact with the contact surface, resulting in a constantly low contact resistance.

MULTILAM Technology allows to find solutions for connectors within the severest constraints and in certain products for up to 1 million mating cycles.

This makes the MULTILAM Technology the best choice for applications with demanding requirements:

- Reliable and longlife operation due to constantly high performance
- Safe operation under highest environmental demands on temperature, vibration and shock
- Suitable for data and signal contacts as well as high-current connectors
- Automated solutions with a high number of mating cycles

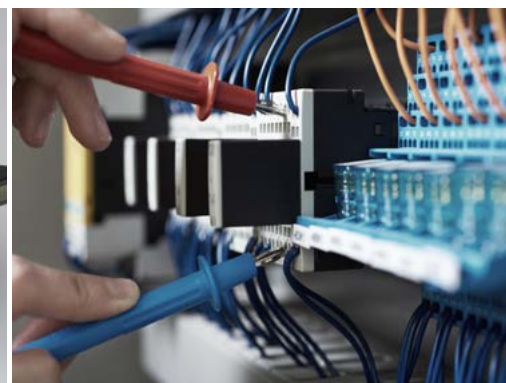

Technical information

Fork plug terminations

have to be made flexible so that the floating mounting of the fork plug body in the insulating housing is not impaired. When the fork plug is used without insulating housing, at least one part must be terminated and fastened in a floating manner (busbar or fork plug).

Plating

The copper and aluminium busbars should be plated with a thin layer of silver.

Lubrication

of the contact area (busbar) with contact grease is recommended.

Lubricant

Stäubli recommends the following lubricants:

Klübertemp® GR UT 18*

Kontasynth BA100 Spray (73.1051)*

Sliding grease in SF6-gas:

Barrierta I EL-102*

Assembly and sealing grease:

Barrierta I S-402 or Barrierta I MI-202*

Touch protection

The fork plug is not a touchproof safety plug, therefore the 5 safety rules according to EN 50110-1 must be observed when working with it.

Withdrawal and mating forces

The stated figures refer to forces after 20 – 30 mating cycles with a thin film of lubricant present. Forces are greater in the new condition.

Rated current

(IEC 61984) Amperages and temperatures were measured at 20 °C ambient temperature after 2 hours load. (Final temperature about 70 °C-80 °C).

Rated voltage (IEC 61984)

Voltage assigned by Stäubli to the connector and to which the operation and performance characteristics refer.

Note: A connector may have more than one voltage value.

Contact resistance

is the resistance occurring at the contact point of two contact surfaces. Its value is calculated from the measured voltage drop at the rated current.

Test voltage

is the voltage withstood by a plug connector under predetermined test conditions, without breakdown or flashover.

Flashover voltage

is the withstand alternating voltage at which flashover can arise.

The values in the tables apply between active parts and the attachment plane.

Rated peak withstand current

As defined by IEC 60909:1988.

Insulation coordination

according to IEC 60664-1. Indicate the rated surge voltage in kV and the degree of pollution.

Mating cycles

The maximum number of mating cycles of the standard plug-in connections is between 1000 and 5000, depending on duty conditions. Precondition is a thin film of lubricant on the contacts prior to initial mating.

Because higher cycle numbers call for special surface treatment, guiding and lubrication measures, each case must be individually investigated to establish the required measures.

Protection against electric shock

For an unenclosed connector, protection against electric shock must be provided by the enclosure of the end-use-product, in which the connector is installed.

Crimp terminations

For conductor terminations, we recommend hexagonal crimping for our crimp sleeves. Afterwards the sleeve can be notched with a drift. Our crimp sleeves are designed for highly flexible Cu conductors. Special crimp sleeves are required for other types of conductors. Stäubli recommends Elpress for all highly flexible conductors.

Screw clamping terminals

When flexible or highly flexible leads are connected, use wire sleeves.

Employed plastic materials		
Symbol	Material description	Temperature°C
PC	Polycarbonate	-80°C...+125°C
ABS	Acrylnitril-Butadien-Styrol-Copolymere	-40°C...+90°C
PA66	Polyamide 66	-40°C...+144°C
PPO	Polyphenylene oxide	-40°C...+140°C

* from Klüber Lubrication, München

Engineering considerations per UL Underwriters Laboratories Inc.



applicable for connectors of series

P1/30 (pages 6 – 7)

P1/63 (pages 8 – 11)

P1/100 (pages 16 – 17)

P4/50 (pages 12 – 13)

P4/63 (pages 12 – 13).

Technical data and ratings:

See pages with the general description of each type.

These devices are multi-pole or single-pole connectors with contacts employing crimp and screw type terminations intended for use in electrical equipment.

Use

- These devices are for use only in complete equipment where the acceptability of the combination is confirmed by Underwriters Laboratories Inc.
- Tested according to United States Standard UL 1977, First Edition, Standard for Component Connectors for Use in Data, Signal, Control, and Power Applications. (and Canadian National Standard CSA C22.2 No. 182.3-M1).

Conditions of Acceptability

In order to be judged acceptable as a component of electrical equipment, the following conditions shall be met:

1. These devices should be used only where they will not interrupt current.
2. The suitability of the mode of installation shall be determined in the end use.
3. The dielectric Voltage Withstand Test (AC) has been conducted between adjacent poles at a potential as stated in the tables, (see under Test voltage).
4. The operating temperature of these devices should not exceed the temperature ratings of the insulating materials as stated in the tables (see under Temperature range).
5. These devices are not intended to absorb any strain from the conductors.
6. Spacings provided through air and over surface between live metal parts of opposite polarity, between live parts and exposed non current carrying metal parts. These devices may be used at potentials
 - ≤ 250 V based on a minimum of 3/64 inch (1.2 mm), or
 - 600 V based on a minimum of 1/8 inch (3.2 mm). Spacings specified by UL 1977.

UL 1977:

Section 17:

Dielectric Voltage Withstand Test

Section 14:

Mold Stress Test

Section 16:

Temperature Test, investigated for a current test with metric wires carried by each contact)

Section 19:

Conductor Secureness Test

UL 498:

Section 62:

Insulation Resistance Test

Section 63:

Conductor Secureness Test

Test record summary:

The results of the investigation indicate that the connectors evaluated comply with the applicable requirements, and are judged eligible to bear  Marking.

Index

Sorted by type

Type	Order No.	Page
B4-P4/50-B	01.0410	13
B6-P1/100-S	01.0405	19
B-GSR	10.5023	26
BP4-P1/63-10	01.0414	11
BP6-P1/100-16	01.0406	17
D-P4/50PC	15.5035	11, 13
EBB8-V0	01.0474	22
EBB10-V0	01.0475	22
EBB14-V0	01.0431	22
EBS8-V0	04.0427	22
EBS10-V0	04.0428	22
EBS14-V0	04.0431	22
F/M10 DIN6798A BN91220	08.0716	26
G-GSR5/10	10.5005	25
G-GSR5/16	10.5006	25
G-GSR5/25	10.5007	25
G-GSR5/35	10.5008	25
G-GSR5/50	10.5009	25
G-GSR5/70	10.5010	25
G-GSR5/B-M10x50	10.5012	26
G-GSR5/M10	10.5011	26
GS-P1/100	15.5253	19
GSRD5-25	10.0031	34
GSRD5-50	10.0032	34
GSRD5-75	10.0033	34
GSRD5-100	10.0034	34
GSRD6/6,35-25	10.0035	34
GSRD6/6,35-50	10.0036	34
GSRD6/6,35-75	10.0037	34
GSRD6/6,35-100	10.0038	34
GSRD10-25	10.0039	34
GSRD10-50	10.0040	34
GSRD10-75	10.0041	34
GSRD10-100	10.0042	34
GWD-STI M6x12 ISO4026 BN28 DIN913 45H	15.5253	17
I-GSR5	10.5020	27
I-P1/63-B	15.5256	11, 13
I-P1/63-S	15.5255	11, 13
I-P1/100-B	15.5252	17, 19
I-P1/100-S	15.5251	17, 19
MU0,5D/M10 AG	08.0006	26
MU0,8D/M10 AG	08.0106	26

Type	Order No.	Page
MU-GSR5	10.5024	27
P1/30-BS	15.0188	9
P1/30-SSK	15.0186	9
P1/30-SSL	15.0187	9
P1/63-B10	15.0184	11
P1/63-BS	15.0164	13
P1/63-S10K	15.0180	11
P1/63-S10L	15.0182	11
P1/63-SSK	15.0160	13
P1/63-SSL	15.0162	13
P1/100-B16	15.0172	17
P1/100-BS	15.0152	19
P1/100-S16K	15.0170	17
P1/100-S16L	15.0171	17
P1/100-SSK	15.0150	19
P1/100-SSL	15.0151	19
P4/50-B	15.0112	15
P4/50-B-D	15.0116	15
P4/50-S	15.0111	15
P4/50-S-D	15.0115	15
P4/63-B-PC	15.0114	15
P4/63-B-PCD	15.0118	15
P4/63-S-PC	15.0113	15
P4/63-S-PCD	15.0117	15
S4-P4/50-S17	04.0410	13
S4-P4/50-S19	04.0413	13
SCH-GSR5	10.5022	27
SCH-P4/50	15.5032	11, 13
S-GSR5	10.5021	27
SP4-P1/63-10K	05.0403	11
SP4-P1/63-10L	05.0404	11
SP6-P1/100-16K	05.0400	17
SP6-P1/100-16L	05.0401	17
SP6-P1/100-SK	04.0401	19
SP6-P1/100-SL	04.0402	19
U/M10 AG	08.0306	26

Index

Sorted by order no.

Order No.	Type	Page
01.0405	B6-P1/100-S	19
01.0406	BP6-P1/100-16	17
01.0410	B4-P4/50-B	13
01.0414	BP4-P1/63-10	11
01.0431	EBB14-V0	22
01.0474	EBB8-V0	22
01.0475	EBB10-V0	22
04.0427	EBS8-V0	22
04.0428	EBS10-V0	22
04.0431	EBS14-V0	22
08.0006	MU0,5D/M10 AG	26
08.0106	MU0,8D/M10 AG	26
08.0716	F/M10 DIN6798A BN91220	26
10.0031	GSRD5-25	34
10.0032	GSRD5-50	34
10.0033	GSRD5-75	34
10.0034	GSRD5-100	34
10.0035	GSRD6/6,35-25	34
10.0036	GSRD6/6,35-50	34
10.0037	GSRD6/6,35-75	34
10.0038	GSRD6/6,35-100	34
10.0039	GSRD10-25	34
10.0040	GSRD10-50	34
10.0041	GSRD10-75	34
10.0042	GSRD10-100	34
10.5005	G-GSR5/10	25
10.5006	G-GSR5/16	25
10.5007	G-GSR5/25	25
10.5008	G-GSR5/35	25
10.5009	G-GSR5/50	25
10.5010	G-GSR5/70	25
10.5011	G-GSR5/M10	26
10.5012	G-GSR5/B-M10x50	26
10.5020	I-GSR5	27
10.5023	B-GSR	26
10.5024	MU-GSR5	27
15.0160	P1/63-SSK	13
15.0164	P1/63-BS	13
15.0180	P1/63-S10K	11
15.0182	P1/63-S10L	11
15.0184	P1/63-B10	11
15.0186	P1/30-SSK	9

Order No.	Type	Page
15.0187	P1/30-SSL	9
15.0188	P1/30-BS	9
15.5035	D-P4/50PC	11, 13
15.5251	I-P1/100-S	17, 19
15.5252	I-P1/100-B	17, 19
15.5253	GS-P1/100	19
15.5253	GWD-STI M6x12 ISO4026 BN28 DIN913 45H	17
15.5255	I-P1/63-S	11, 13
15.5256	I-P1/63-B	11, 13
15.0115	P4/50-S-D	17
15.0116	P4/50-B-D	17
15.0117	P4/63-S-PCD	17
15.0118	P4/63-B-PCD	17
15.0150	P1/100-SSK	21
15.0151	P1/100-SSL	21
15.0152	P1/100-BS	21
15.0160	P1/63-SSK	15
15.0162	P1/63-SSL	15
15.0164	P1/63-BS	15
15.0170	P1/100-S16K	19
15.0171	P1/100-S16L	19
15.0172	P1/100-B16	19
15.0180	P1/63-S10K	13
15.0182	P1/63-S10L	13
15.0184	P1/63-B10	13
15.0186	P1/30-SSK	11
15.0187	P1/30-SSL	11
15.0188	P1/30-BS	11
15.5032	SCH-P4/50	13, 15
15.5035	D-P4/50PC	13, 15
15.5251	I-P1/100-S	19, 21
15.5252	I-P1/100-B	19, 21
15.5253	GS-P1/100	21
15.5253	GWD-STI M6x12 ISO4026 BN28 DIN913 45H	19
15.5255	I-P1/63-S	13, 15
15.5256	I-P1/63-B	13, 15



● Stäubli Units ○ Representatives/Agents

Global presence of the Stäubli Group

www.staubli.com

丸紅エレネクト株式会社

〒530-0003 大阪市北区堂島1丁目6番20号 TEL : 06-6344-2111 FAX : 06-6346-6611
URL : <https://www.m-elenext.co.jp>

特殊部品カンパニー

新横浜支店 (045-474-9524) ・名古屋支店 (052-201-7071) ・大阪支店 (06-7656-3690)

事業所

仙台支店 ・ 関東支店 川越オフィス ・ 関東支店 新横浜オフィス ・ 浜松支店 ・ 名古屋支店 ・ 北陸出張所 (富山)
京滋支店 (京都) ・ 大阪支店 ・ 姫路支店 ・ 四国支店 (高松) ・ 九州支店 (福岡)

Marubeni
Ele-Next

